

5 Parts List

PL 1 - Standby Power

PL 1.10 HVPS.....	5-3
PL 1.12 SMPS.....	5-4

PL 2 - User Interface

PL 2.10 User Interface	5-5
------------------------------	-----

PL 3 - Machine Run Control

PL 3.10 Main PWB and Main Drive Assembly	5-6
--	-----

PL 4 - Main Drive Assembly

PL 4.10 Main Drive Assembly	5-7
-----------------------------------	-----

PL 5 - DADF

PL 5.10 DADF (1 of 7).....	5-8
PL 5.15 DADF (2 of 7).....	5-9
PL 5.20 DADF (3 of 7).....	5-10
PL 5.25 DADF (4 of 7).....	5-11
PL 5.30 DADF (5 of 7).....	5-12
PL 5.35 DADF (6 of 7).....	5-13
PL 5.40 DADF (7 of 7).....	5-14

PL 6 - Imaging

PL 6.10 LSU.....	5-15
------------------	------

PL 7 - Paper Supply

PL 7.10 Bypass Feed Assembly (1 of 2).....	5-16
PL 7.12 Bypass Feed Assembly (2 of 2).....	5-17
PL 7.15 Front Cover Assembly	5-18

PL 8 - Paper Transport

PL 8.10 Paper Tray.....	5-19
PL 8.15 Tray 2 Assembly (1 of 2).....	5-20
PL 8.17 Tray 2 Assembly (2 of 2).....	5-21
PL 8.20 Rear Cover Assembly.....	5-22
PL 8.25 Registration Rolls.....	5-23

PL 9 - Xerographics

PL 9.10 Print Cartridge.....	5-24
------------------------------	------

PL 10 - Fusing and Copy/Print Transportation

PL 10.10 Fuser Assembly (1 of 3).....	5-25
PL 10.12 Fuser Assembly (2 of 3).....	5-26
PL 10.15 Fuser Assembly (3 of 3).....	5-27
PL 10.20 Duplex Drive Assembly.....	5-28
PL 10.22 Front Duplex Guide Assembly	5-29
PL 10.23 Duplex Assembly (1 of 3).....	5-30
PL 10.25 Exit Feed Assembly	5-31
PL 10.30 Exit Cover Assembly.....	5-32

PL 11 - Stapler Assembly

PL 11.10 Stapler Assembly	5-33
---------------------------------	------

PL 14 - Scanner

PL 14.10 Scanner Assembly	5-34
---------------------------------	------

PL 28 - Main Covers

PL 28.10 Main Covers.....	5-35
---------------------------	------

PL 1.10 HVPS

Item	Part	Description
1	-	Tray 1 paper empty sensor harness (Not Spared)
2	-	HVPS harness (Not Spared)
3	105N02141	HVPS (REP 1.2)
4	-	HVPS insulation sheet (Not Spared)
5	-	HVPS shield (Not Spared)
6	-	HVPS assembly (Not Spared)

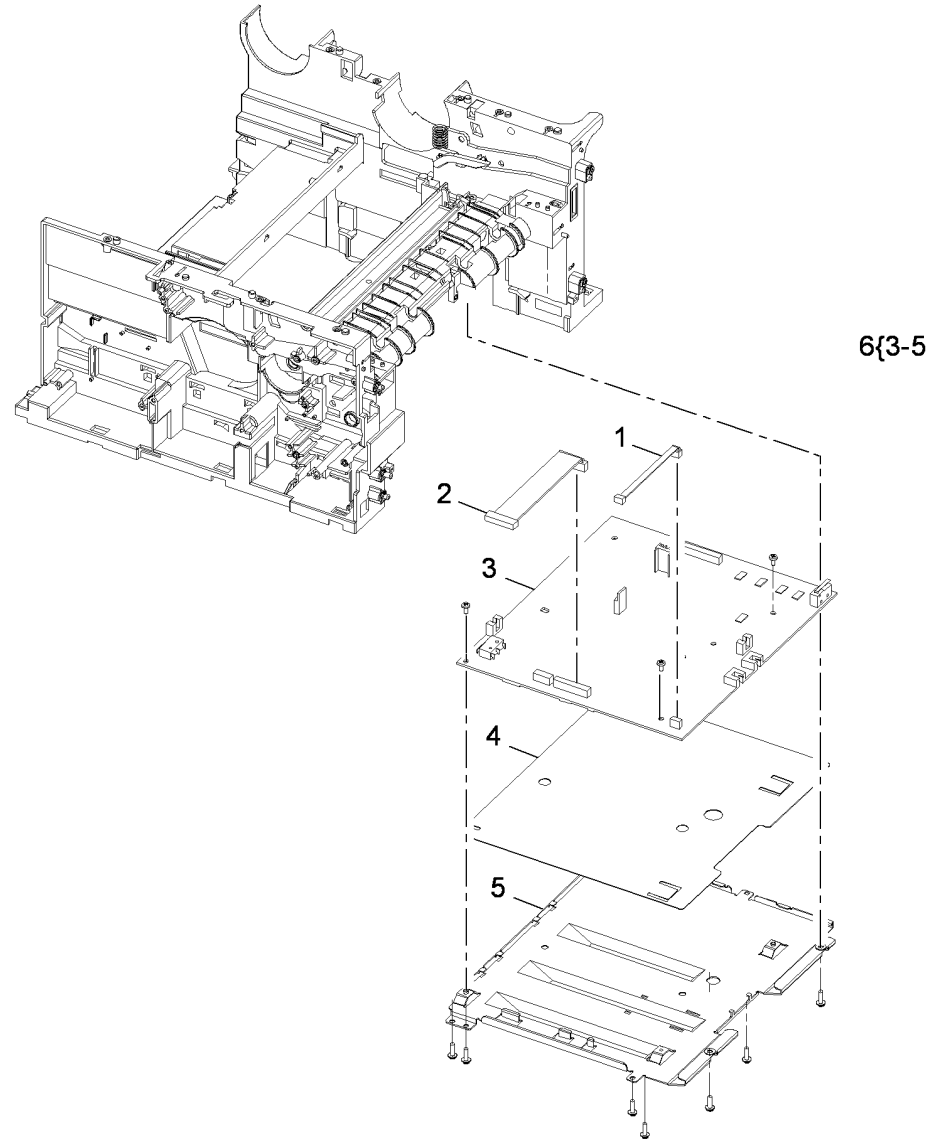

AP-8-1500-A

PL 1.12 SMPS

Item	Part	Description
1	127N07354	SMPS fan
2	-	SMPS cover (Not Spared)
3	105N02119	SMPS (110V) (REP 1.1)
-	105N02143	SMPS (220V) (REP 1.1)
4	-	SMPS harness (Not Spared)
5	-	SMPS insulation sheet (Not Spared)
6	-	Main power socket (Not Spared)
7	-	SMPS shield (Not Spared)
8	-	SMPS assembly (Not Spared)
9	127N07559	Main fan

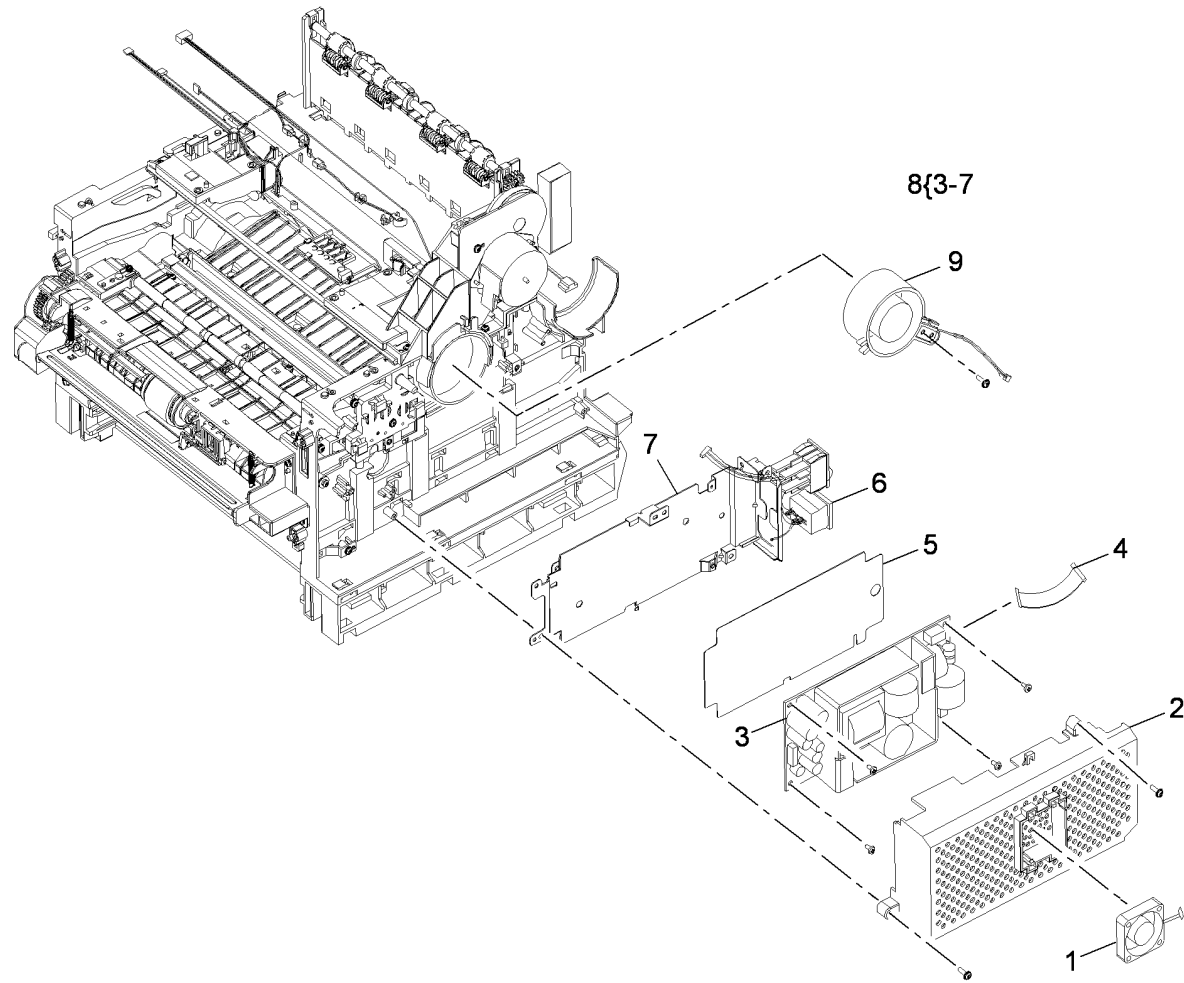

AP-8-1532-A

PL 2.10 User Interface

Item	Part	Description
1	140N63296	Front cover panel
2	-	Key harness (P/O PL 2.10 Item 27)
3	-	Sub-key harness (P/O PL 2.10 Item 27)
4	091N80272	Start button label (English)
-	091N80276	Start button label (French)
-	091N80275	Start button label (Symbol)
5	-	Housing (P/O PL 2.10 Item 27)
6	029N00384	Language key
7	029N00385	Machine status key
8	029N00386	Login/out key
9	029N00387	Help key
10	029N00388	Numerical keys
11	029N00389	Power key
12	029N00390	Power key holder
13	029N00391	Interrupt key
14	029N00392	Job interrupt key
15	029N00393	Stop key
16	029N00394	Start key
17	029N00396	Rubber key mat (left hand side)
18	029N00397	Rubber key mat (right hand side)
19	140N63295	Right keys PWB
20	-	Left keys PWB (P/O PL 2.10 Item 27)
21	091N80273	Services label (English)
-	091N80278	Services label (French)
-	091N80277	Services label (Symbol)
22	091N80274	Numeric key pad label (English)
-	091N80280	Numeric key pad label (French)
-	091N80279	Numeric key pad label (Symbol)
23	015N00618	Name label
24	140N63294	UI PWB (REP 2.2)
25	123N00250	Touch screen (REP 2.2)
26	-	Touchscreen housing (P/O PL 2.10 Item 27)
27	123N00251	UI assembly (Complete) (REP 2.1)

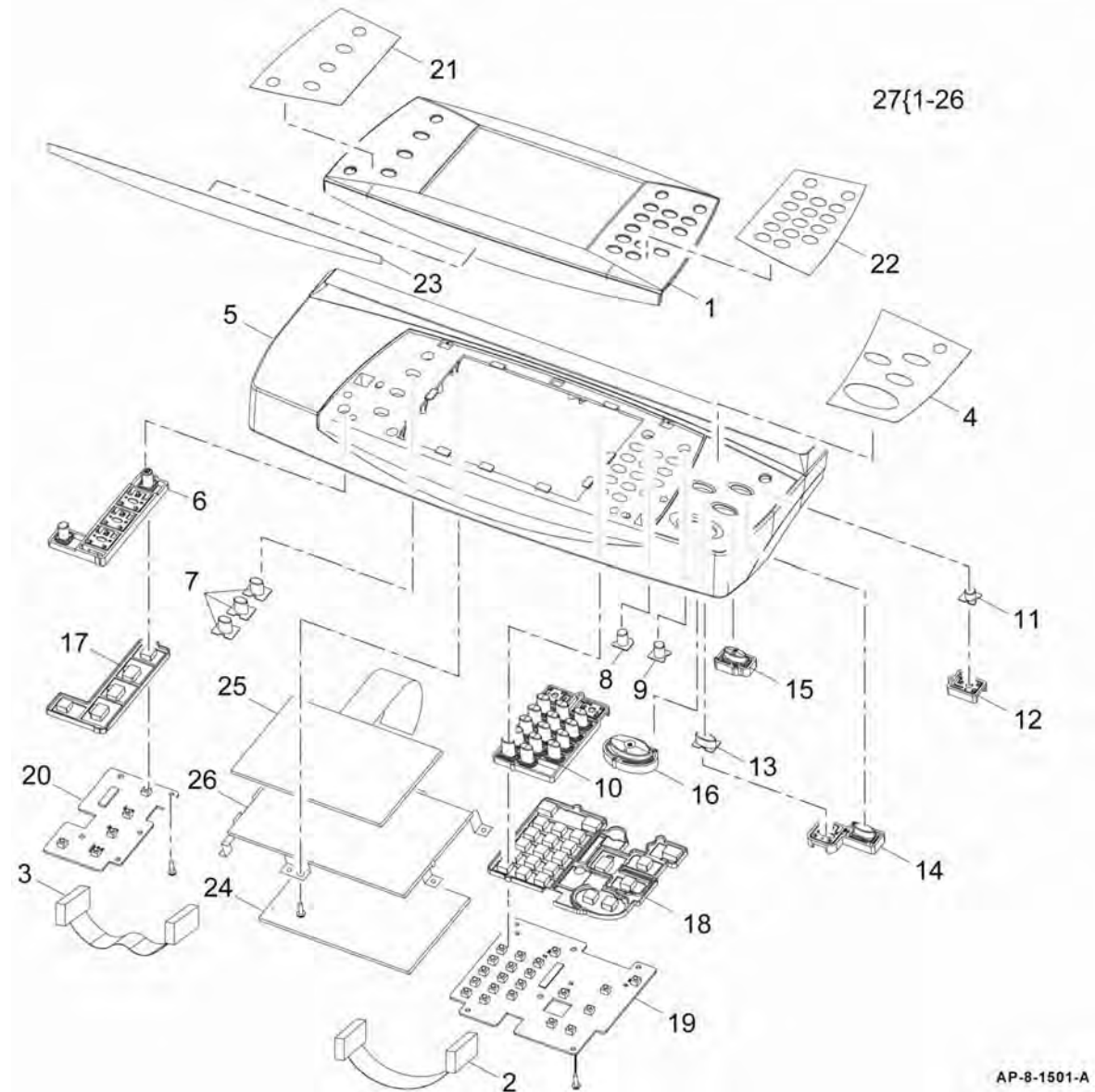

AP-8-1501-A

PL 3.10 Main PWB and Main Drive Assembly

Item	Part	Description
1	-	Main drive assembly (REF: PL 4.10 Item 7)
2	130N01532	Speaker
3	140N63305	FAX PWB (Serial)
-	140N63304	FAX PWB (Parallel)
4	-	FAX harness (Not Spared)
5	-	FAX cover (Not Spared)
6	140N63297	Main PWB (REP 3.1)
7	-	Foreign device interface PWB (Note)
8	113N01308	SIM card holder
9	-	Main PWB bracket (Not Spared)
10	140N63298	Memory DIMM
11	140N63299	USB host PWB (REP 3.2)
12	-	Ground strip (Not Spared)
13	117N01789	USB harness (REP 3.2)
14	-	MSOK (Not Spared)
15	-	Hard drive cover (Not Spared)
16	007N01596	Hard disk drive
17	140N63303	Connection PWB

NOTE: Part number not available at time of launch.

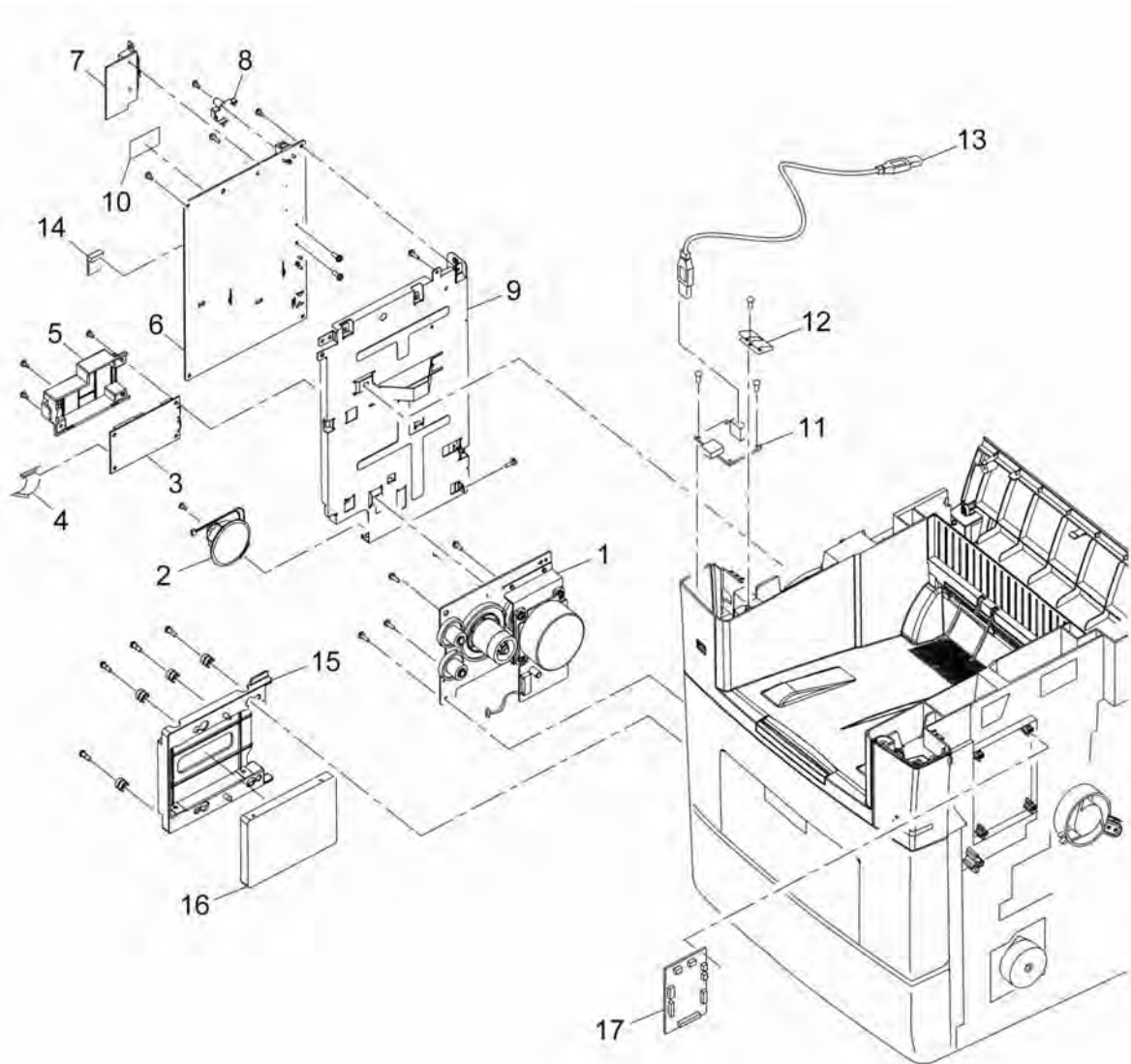

AP-8-1533-A

PL 4.10 Main Drive Assembly

Item	Part	Description
1	127N07557	Main BLDC motor (MOT04-100) (REP 4.1)
2	–	Gear bracket (P/O PL 4.10 Item 7) (REP 4.1)
3	–	Motor bracket (P/O PL 4.10 Item 7)
4	–	Gear (92/61) (P/O PL 4.10 Item 7)
5	–	Gear (113/33) (P/O PL 4.10 Item 7)
6	–	Gear (55/18) (P/O PL 4.10 Item 7)
7	007N01591	Main drive assembly (REP 4.1)

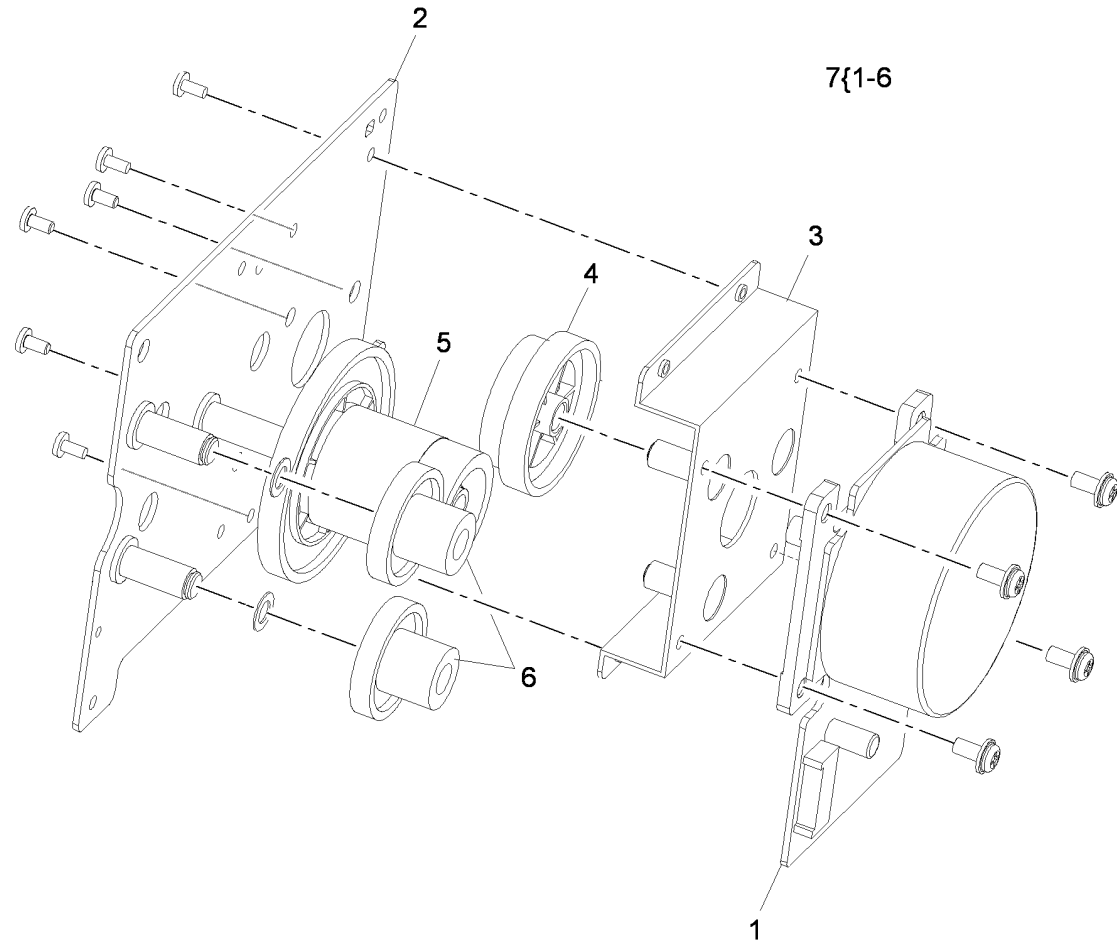

AP-8-1502-A

PL 5.10 DADF (1 of 7)

Item	Part	Description
1	101N01421	DADF (Complete)
2	-	DADF lower cover assembly (P/O PL 5.10 Item 1)
3	-	DADF door assembly (REF: PL 5.25 Item 1)
4	-	Feed assembly (REF: PL 5.30 Item 1)
5	-	Drive assembly (REF: PL 5.40 Item 1)
6	-	Transport assembly (REF: PL 5.35 Item 14)
7	003N01031	Left counterbalance
8	003N01018	Right counterbalance
9	-	Rear cover (P/O PL 5.10 Item 1)
10	-	Front cover (P/O PL 5.10 Item 1)
11	002N02720	Connector cover
12	152N11751	DADF harness

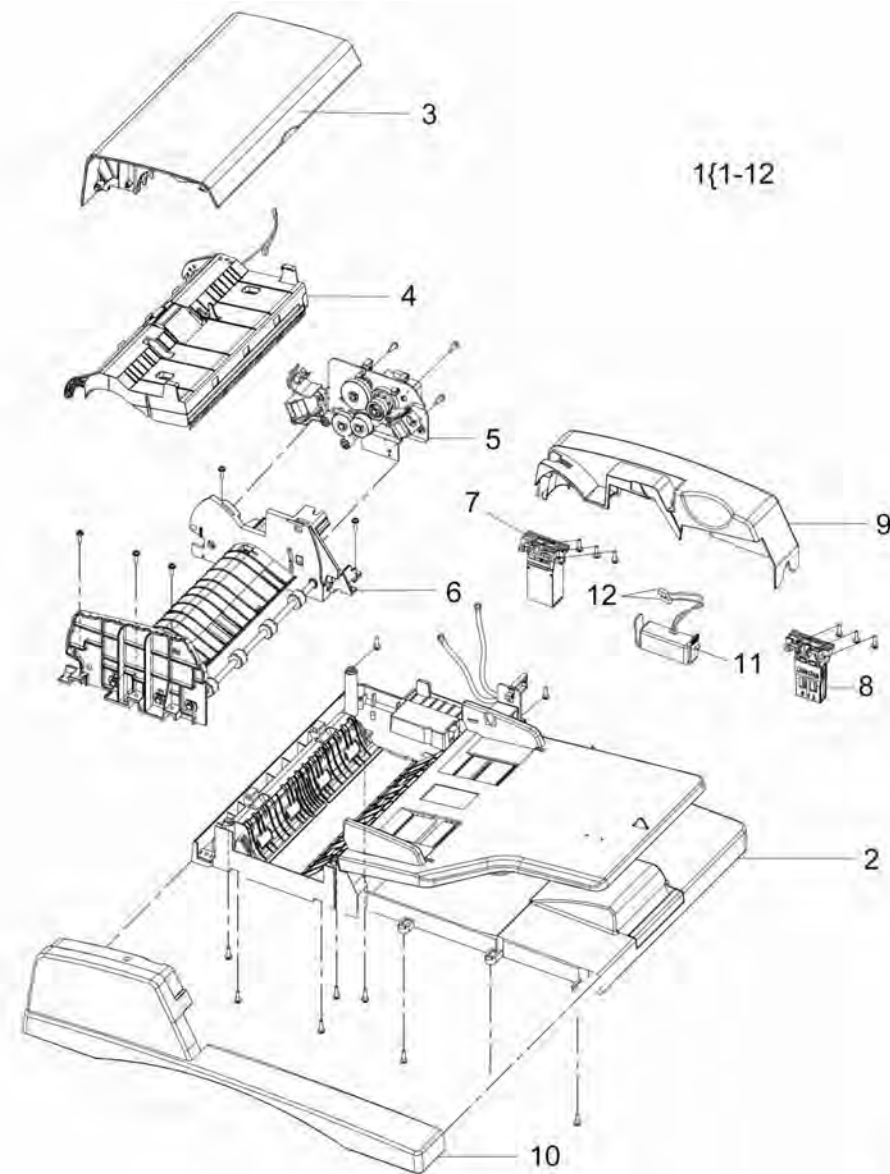

AP-8-1503-A

PL 5.15 DADF (2 of 7)

Item	Part	Description
1	-	Lower cover (P/O PL 5.10 Item 1)
2	-	Input tray assembly (REF: PL 5.20 Item 13)
3	-	Solenoid damper (P/O PL 5.10 Item 1)
4	121N01160	DADF lift solenoid (SOL05-320) (REP 5.2)
5	-	Tray extension (P/O PL 5.10 Item 1)
6	-	Ground strip (P/O PL 5.10 Item 1)
7	095N00340	Document pad
8	-	Registration roll idler (P/O PL 5.10 Item 1)
9	-	Scan idler (P/O PL 5.10 Item 1)
10	-	Scan idler spring (P/O PL 5.10 Item 1)
11	-	Registration roll shaft (P/O PL 5.10 Item 1)
12	-	Nip release lever (P/O PL 5.10 Item 1)
13	-	Nip release lever spring (P/O PL 5.10 Item 1)
14	-	CVT pad (P/O PL 5.10 Item 1)
15	-	Lifting exit lever (P/O PL 5.10 Item 1)
16	140N63301	DADF PWB
17	-	DADF PWB harness (P/O PL 5.10 Item 1)

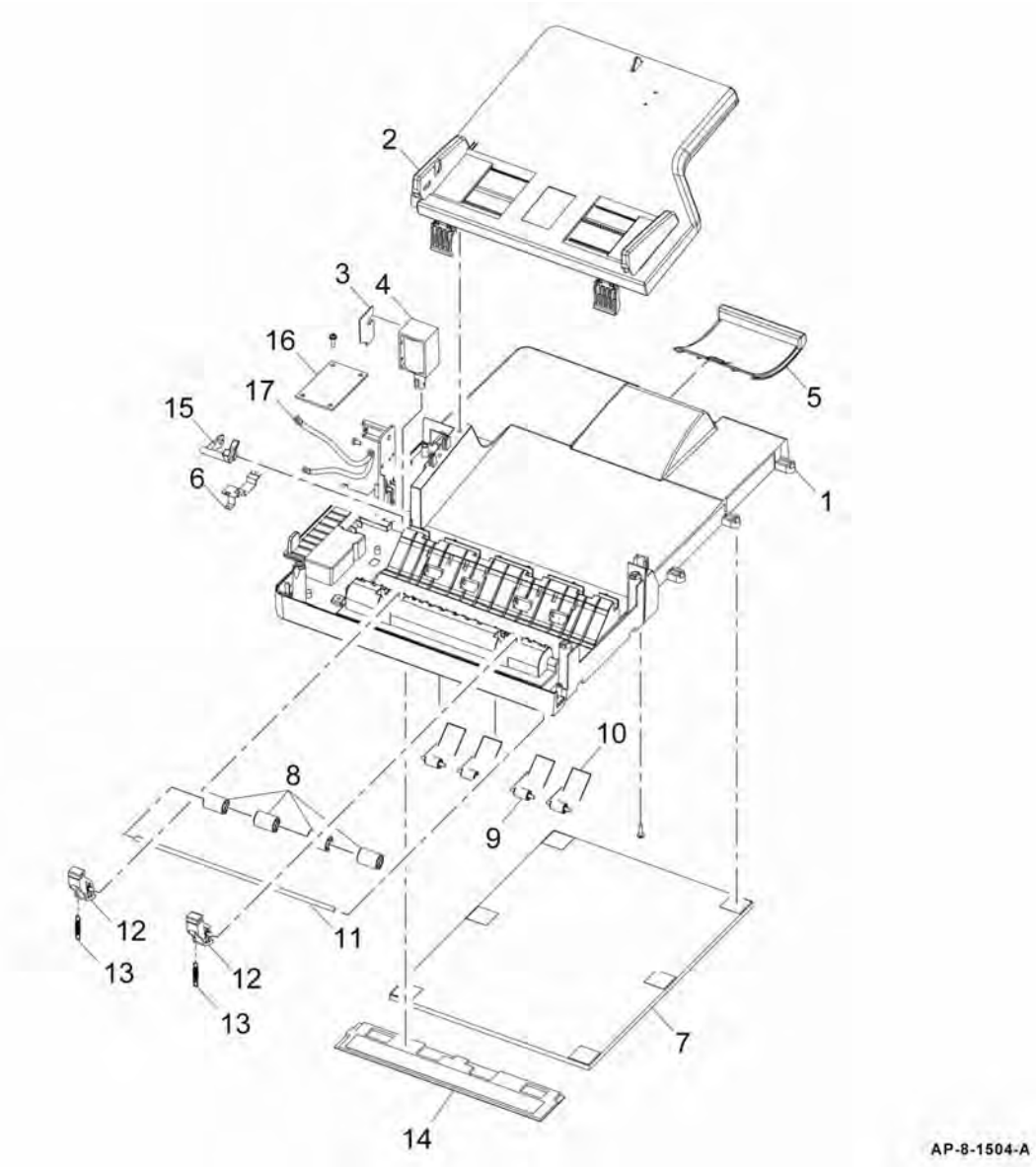

AP-8-1504-A

PL 5.20 DADF (3 of 7)

Item	Part	Description
1	-	Input tray (P/O PL 5.20 Item 13)
2	-	Document guide (rear) (P/O PL 5.20 Item 13)
3	-	Document guide (front) (P/O PL 5.20 Item 13)
4	-	Document guide rack (P/O PL 5.20 Item 13)
5	-	Pinion gear (P/O PL 5.20 Item 13)
6	-	Guide rack cover (P/O PL 5.20 Item 13)
7	-	Document guide (P/O PL 5.20 Item 13)
8	-	Document guide wire (P/O PL 5.20 Item 13)
9	-	DADF paper length sensor actuator (P/O PL 5.20 Item 13)
10	-	DADF paper length sensor spring (P/O PL 5.20 Item 13)
11	130N01274	DADF paper length sensor (Q05-120) (REP 5.6)
12	-	Sensor assembly cover (P/O PL 5.20 Item 13)
13	002N02741	Input tray assembly (Complete)

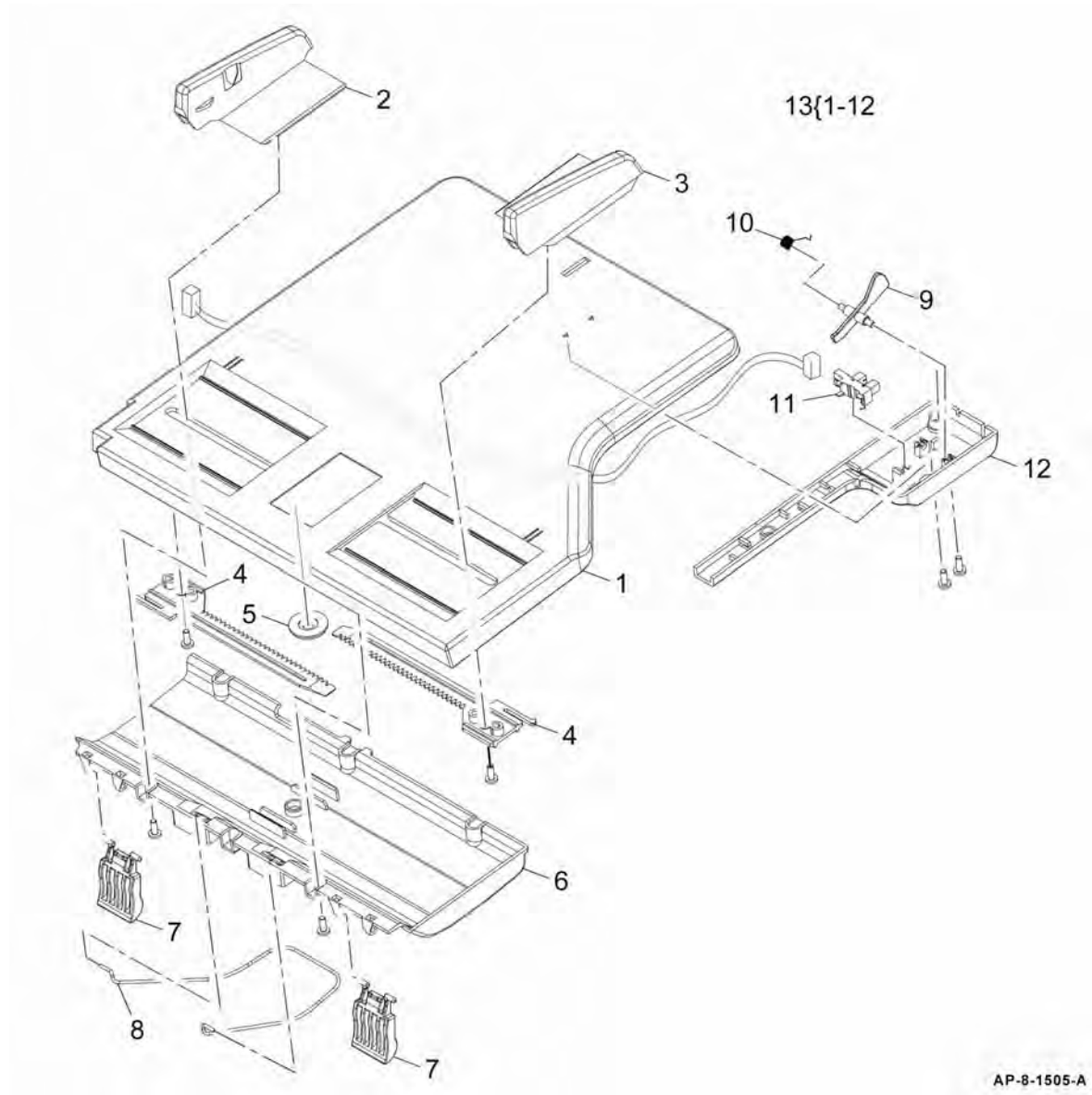

AP-8-1505-A

PL 5.25 DADF (4 of 7)

Item	Part	Description
1	-	DADF door assembly (Complete) (P/O PL 5.10 Item 1)
2	130N01533	Pickup roll assembly (REP 5.7)
3	-	Bush (P/O PL 5.10 Item 1)
4	-	Document gate (P/O PL 5.10 Item 1)
5	-	DADF door (P/O PL 5.10 Item 1)
6	-	Guide fingers (P/O PL 5.10 Item 1)
7	-	Pickup spring (P/O PL 5.10 Item 1)
8	-	Pickup damper (P/O PL 5.10 Item 1)

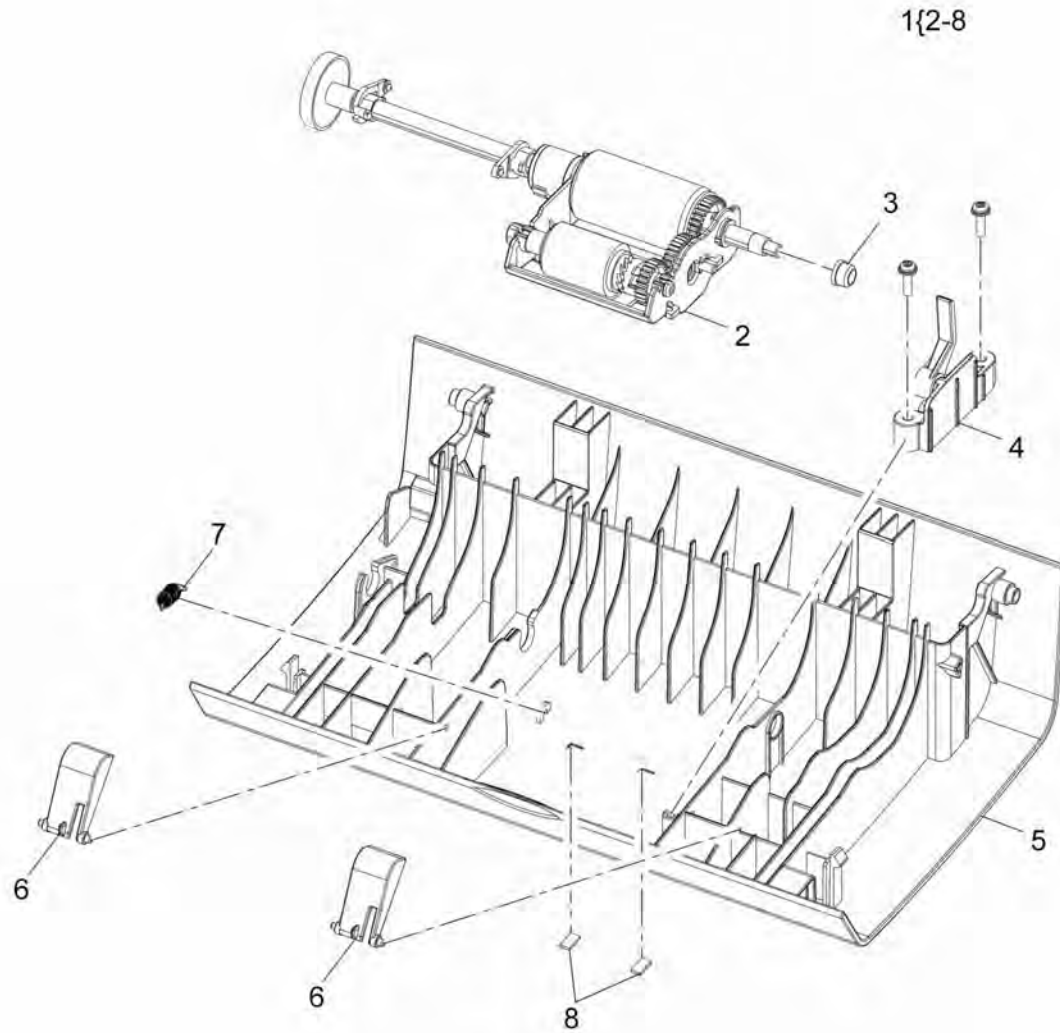

AP-8-1506-A

PL 5.30 DADF (5 of 7)

Item	Part	Description
1	022N02359	Feed assembly (Complete) (REP 5.4)
2	003N01030	Retard pad assembly
3	-	Retard pad spring (P/O PL 5.30 Item 1)
4	-	Feed roll idler (P/O PL 5.30 Item 1)
5	-	Upper cover (P/O PL 5.30 Item 1)
6	-	Mylar (P/O PL 5.30 Item 1)
7	-	Exit idler spring (P/O PL 5.30 Item 1)
8	-	Exit idler (P/O PL 5.30 Item 1)
9	-	Exit idler shaft (P/O PL 5.30 Item 1)
10	-	Exit idler lifting bracket (P/O PL 5.30 Item 1)
11	-	Upper damper (P/O PL 5.30 Item 1)
12	-	Static eliminator (P/O PL 5.30 Item 1)
13	-	Lower cover (P/O PL 5.30 Item 1)
14	-	Ground strip (P/O PL 5.30 Item 1)
15	-	Ground strip (P/O PL 5.30 Item 1)
16	-	Document detect sensor harness (P/O PL 5.30 Item 1)
17	130N01274	Document detect sensor (Q05-100)
18	-	Document detect sensor actuator (P/O PL 5.30 Item 1)
19	-	Document detect sensor actuator spring (P/O PL 5.30 Item 1)

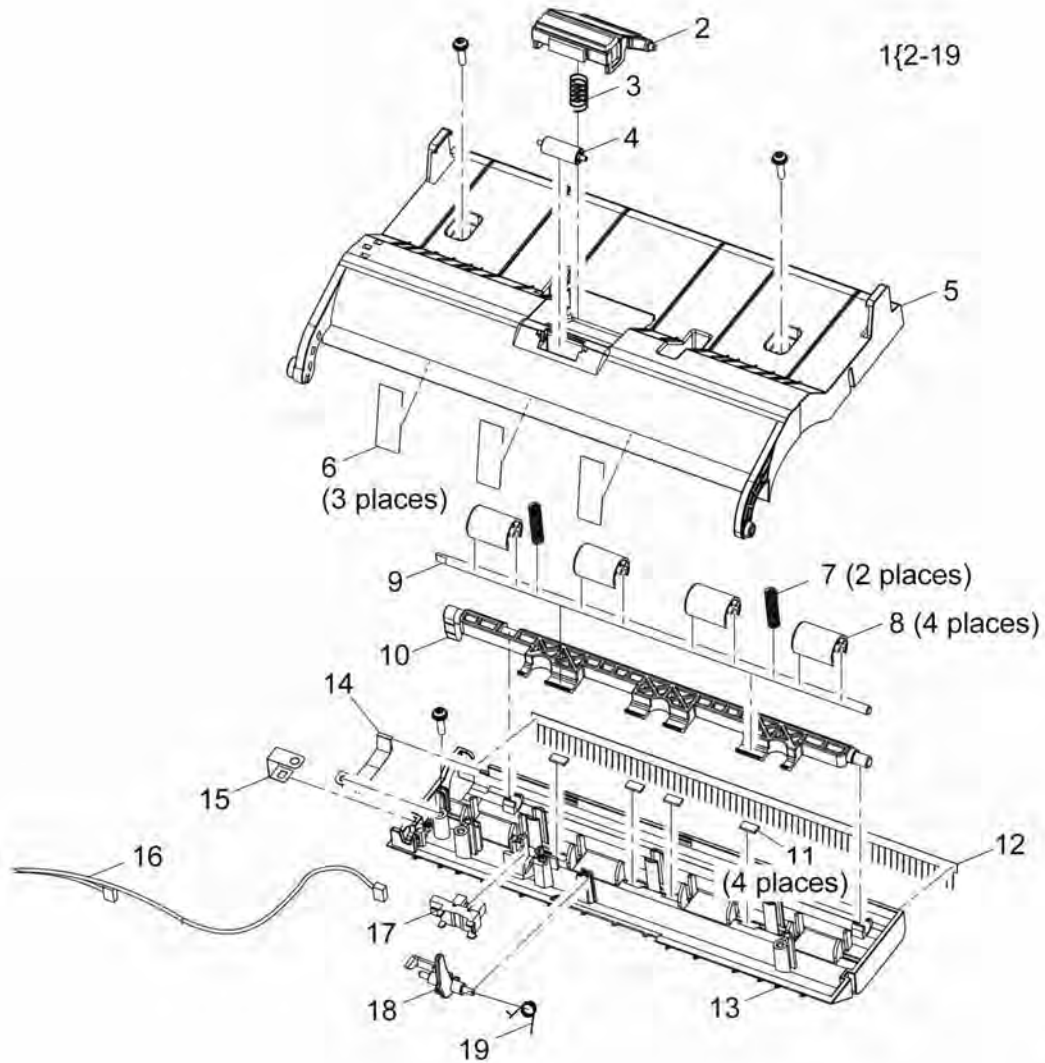

AP-8-1507-A

PL 5.35 DADF (6 of 7)

Item	Part	Description
1	-	Transport assembly frame (P/O PL 5.35 Item 14)
2	-	White bar plate (P/O PL 5.35 Item 14)
3	-	White bar plate spring (P/O PL 5.35 Item 14)
4	-	Bearing (P/O PL 5.35 Item 14)
5	-	Ground strip (P/O PL 5.35 Item 14)
6	-	Scan sensor actuator (P/O PL 5.35 Item 14)
7	130N01274	Registration sensor (Q05-130) (REP 5.3), Scan sensor (Q05-140) (REP 5.3)
8	-	Exit roll (P/O PL 5.35 Item 14)
9	-	Registration roll (P/O PL 5.35 Item 14)
10	-	Registration sensor actuator (P/O PL 5.35 Item 14)
11	-	Registration sensor actuator spring (P/O PL 5.35 Item 14)
12	-	Scan roll (P/O PL 5.35 Item 14)
13	-	Upper cover (P/O PL 5.35 Item 14)
14	022N02360	Transport assembly (Complete) (REP 5.4)

14{1-13

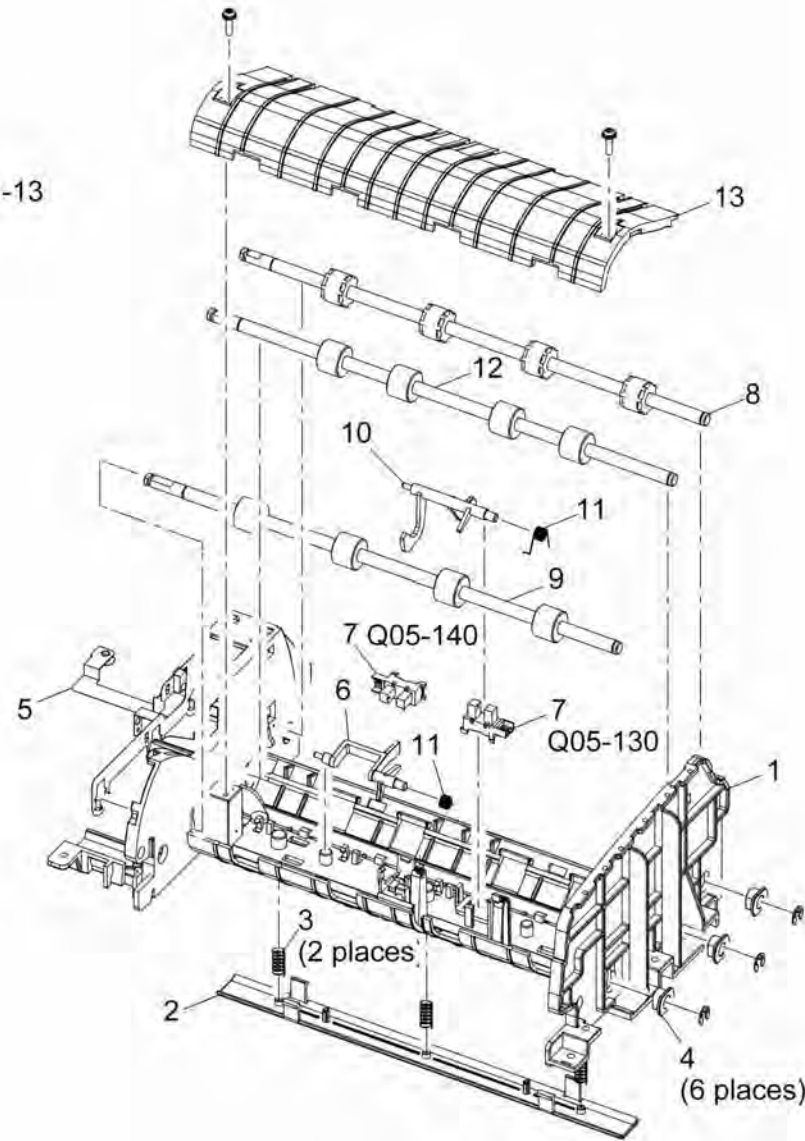

AP-8-1508-A

PL 5.40 DADF (7 of 7)

Item	Part	Description
1	007N01595	Drive assembly (Complete) (REP 5.5)
2	127N07562	Scan motor (MOT05-200) (REP 5.5)
3	121N01161	Registration solenoid (SOL05-310) (REP 5.5), Pickup solenoid (SOL05-300) (REP 5.5)
4	-	Pickup idler gear (P/O PL 5.40 Item 1)
5	-	Swing bracket (P/O PL 5.40 Item 1)
6	-	Swing bracket feed gear idler (P/O PL 5.40 Item 1)
7	-	Swing bracket pickup gear idler (P/O PL 5.40 Item 1)
8	-	Feed gear idler (P/O PL 5.40 Item 1)
9	-	Lower pickup gear idler (P/O PL 5.40 Item 1)
10	-	Pickup collar (P/O PL 5.40 Item 1)
11	-	Spring (P/O PL 5.40 Item 1)
12	-	Upper pickup gear idler (P/O PL 5.40 Item 1)
13	-	DADF door open sensor (Q05-160) (P/O PL 5.40 Item 1) (REP 5.1)
14	-	Motor harness (P/O PL 5.40 Item 1)
15	-	Drive bracket (P/O PL 5.40 Item 1)

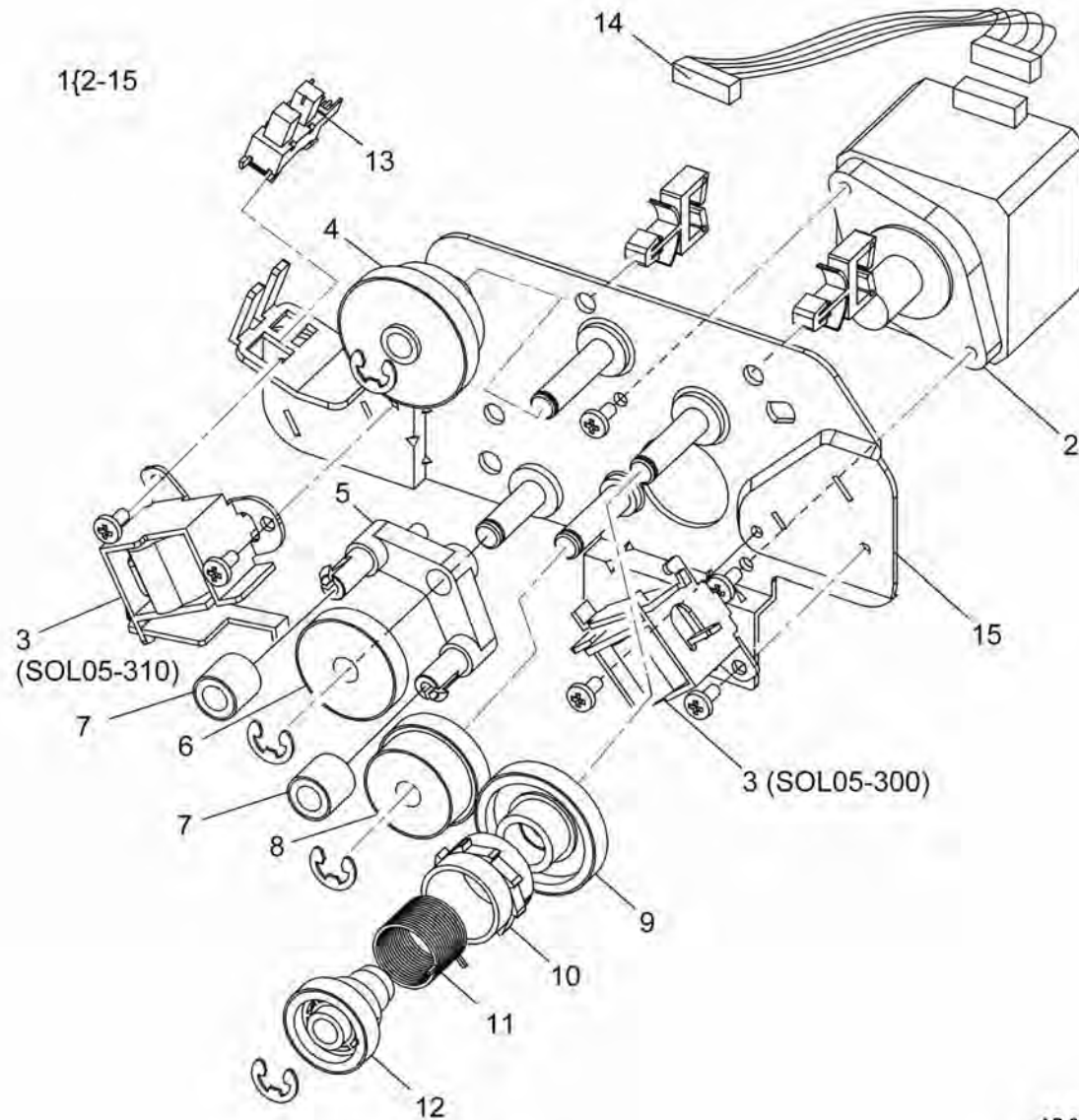

AP-8-1509-A

PL 6.10 LSU

Item	Part	Description
1	122N00259	LSU (REP 6.1)
2	152N11753	LSU interlock switch (REP 6.2)

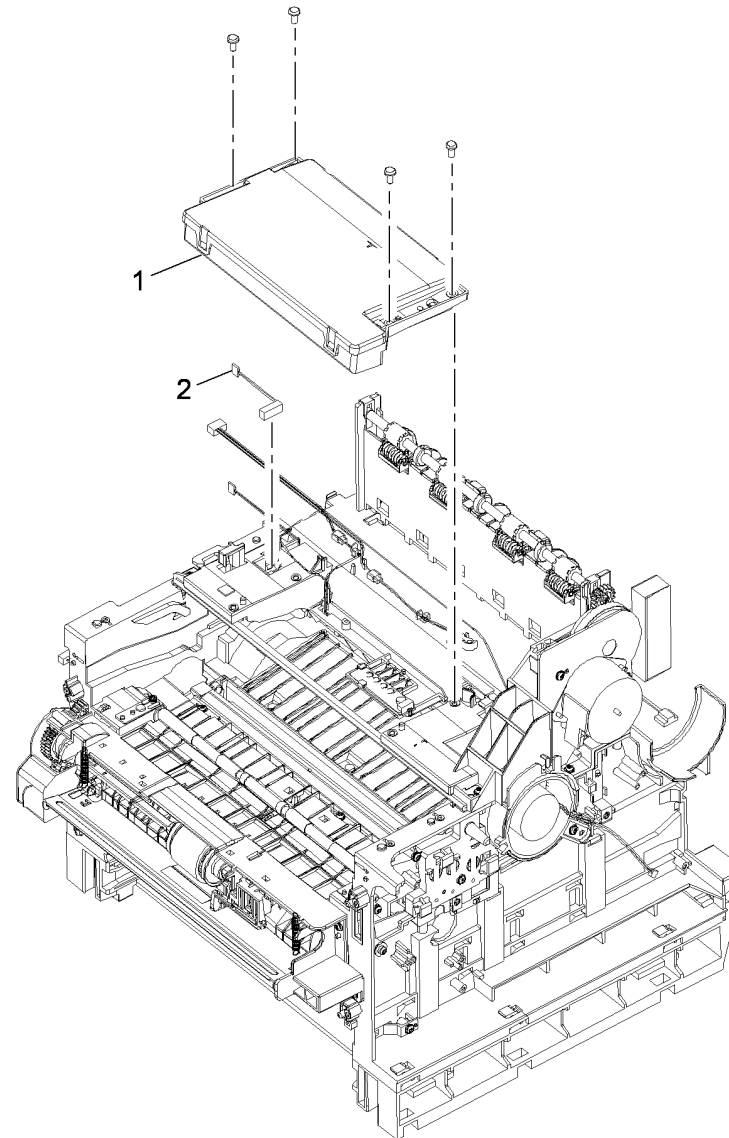

AP-8-1535-A

PL 7.10 Bypass Feed Assembly (1 of 2)

Item	Part	Description
1	130N01274	Bypass paper empty sensor (Q07-510) (REP 7.5)
2	-	Clutch spring (P/O PL 7.10 Item 29)
3	-	Baffle lift spring (P/O PL 7.10 Item 29) (MEXICO)
4	-	Bypass feed solenoid (SOL08-500) (P/O PL 7.10 Item 29)
5	-	Bypass paper empty sensor harness (P/O PL 7.10 Item 29) (REP 7.1)
6	-	Bush (P/O PL 7.10 Item 29)
7	-	Locking collar (P/O PL 7.10 Item 29)
8	-	Retard pad holder (P/O PL 7.10 Item 29)
9	-	Sensor bracket (P/O PL 7.10 Item 29)
10	-	Baffle (P/O PL 7.10 Item 29)
11	-	Pickup bracket (P/O PL 7.10 Item 29)
12	-	Frame (P/O PL 7.10 Item 29)
13	-	Spring (P/O PL 7.10 Item 29)
14	-	Guide mylar (P/O PL 7.10 Item 29)
15	-	Idler gear (P/O PL 7.10 Item 29)
16	-	Pickup shaft (P/O PL 7.10 Item 29)
17	-	Clutch (rear) (P/O PL 7.10 Item 29)
18	-	Clutch (front) (P/O PL 7.10 Item 29)
19	-	Pickup cam (P/O PL 7.10 Item 29)
20	-	Cam roll (P/O PL 7.10 Item 29)
21	-	Pickup idler (P/O PL 7.10 Item 29)
22	-	Bypass paper empty sensor actuator (P/O PL 7.10 Item 29)
23	-	Lower retard pad (P/O PL 7.10 Item 29)
24	-	Pickup rubber outer shaft (P/O PL 7.10 Item 29)
25	-	Pickup rubber inner shaft (P/O PL 7.10 Item 29)
26	130N01534	Pickup rubber
27	-	Retard pad (P/O PL 7.10 Item 29) (NOTE)
28	-	Bypass pickup roll assembly (P/O PL 7.10 Item 29) (NOTE) (REP 7.3)
29	050N00520	Bypass feed assembly (Complete) (REP 7.1)

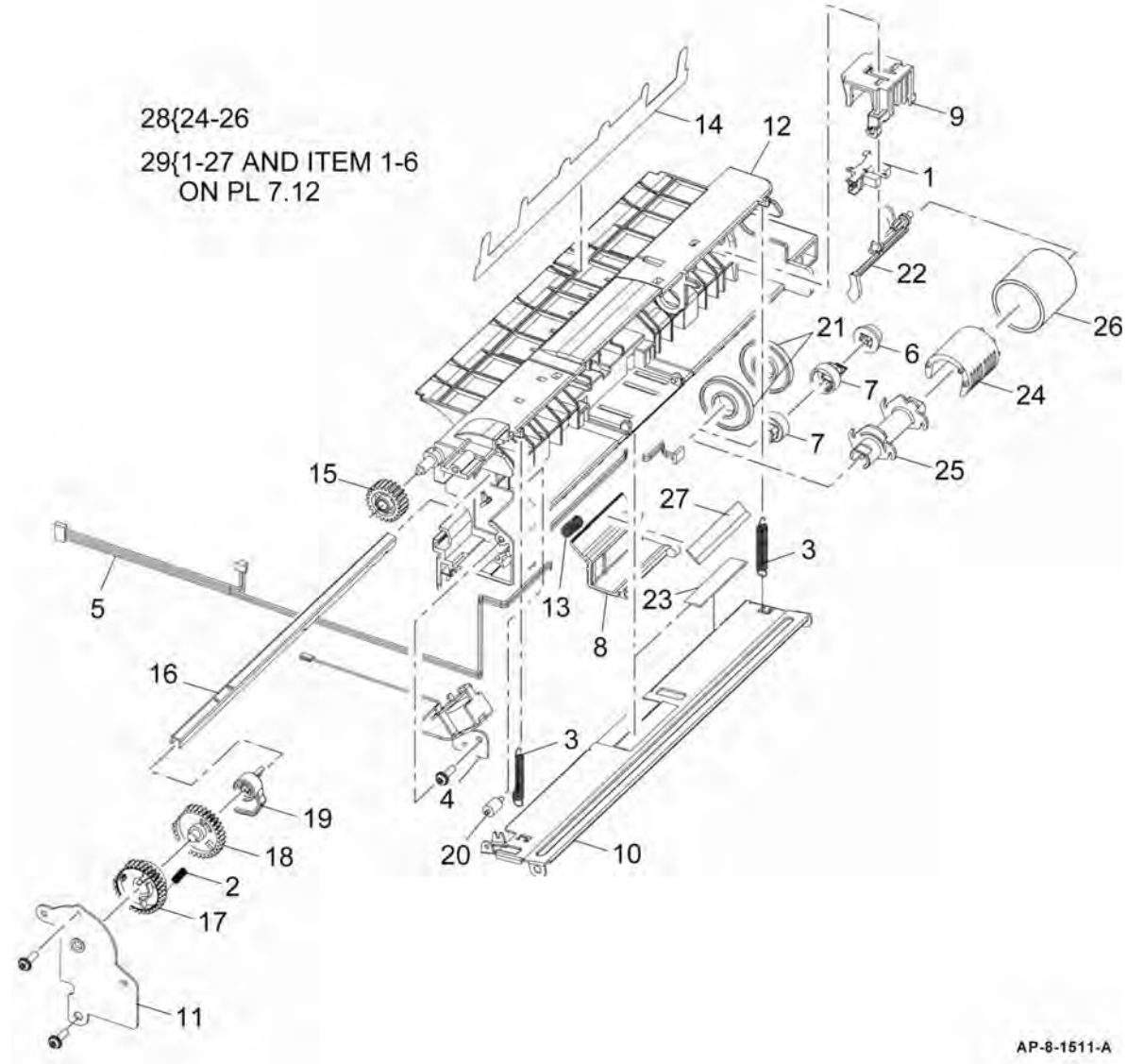

NOTE: HFSI. To reset the HSFI count go to GP 16.

PL 7.12 Bypass Feed Assembly (2 of 2)

Item	Part	Description
1	-	Feed idler holder (P/O PL 7.10 Item 29)
2	-	Lower exit idler spring (P/O PL 7.10 Item 29)
3	-	Feed idler shaft (P/O PL 7.10 Item 29)
4	-	Feed idler shaft holder (P/O PL 7.10 Item 29)
5	-	Feed idler cover (P/O PL 7.10 Item 29)
6	-	Feed roll idler (P/O PL 7.10 Item 29)
7	-	Bypass feed assembly (REF: PL 7.10 Item 29)

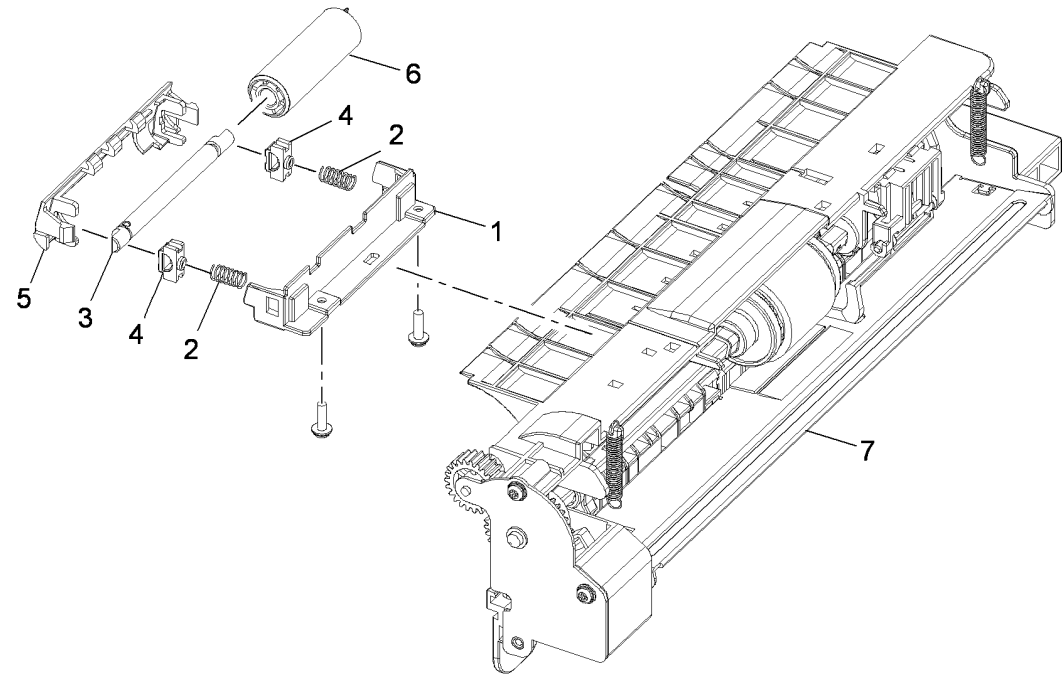

AP-8-1528-A

PL 7.15 Front Cover Assembly

Item	Part	Description
1	-	Front cover (P/O PL 7.15 Item 15)
2	-	Lower bypass tray cover (P/O PL 7.15 Item 15)
3	-	Front document guide (P/O PL 7.15 Item 15)
4	-	Rear document guide (P/O PL 7.15 Item 15)
5	-	Release latch (P/O PL 7.15 Item 15)
6	-	Link arm (P/O PL 7.15 Item 15)
7	-	Upper bypass tray cover (P/O PL 7.15 Item 15)
8	-	Tray extension (P/O PL 7.15 Item 15)
9	-	Front catch (P/O PL 7.15 Item 15)
10	-	Rear catch (P/O PL 7.15 Item 15)
11	-	Pinion gear (P/O PL 7.15 Item 15)
12	-	Front catch spring (P/O PL 7.15 Item 15)
13	-	Rear catch spring (P/O PL 7.15 Item 15)
14	-	Bypass tray (P/O PL 7.15 Item 15)
15	002N02718	Front cover assembly (Complete)

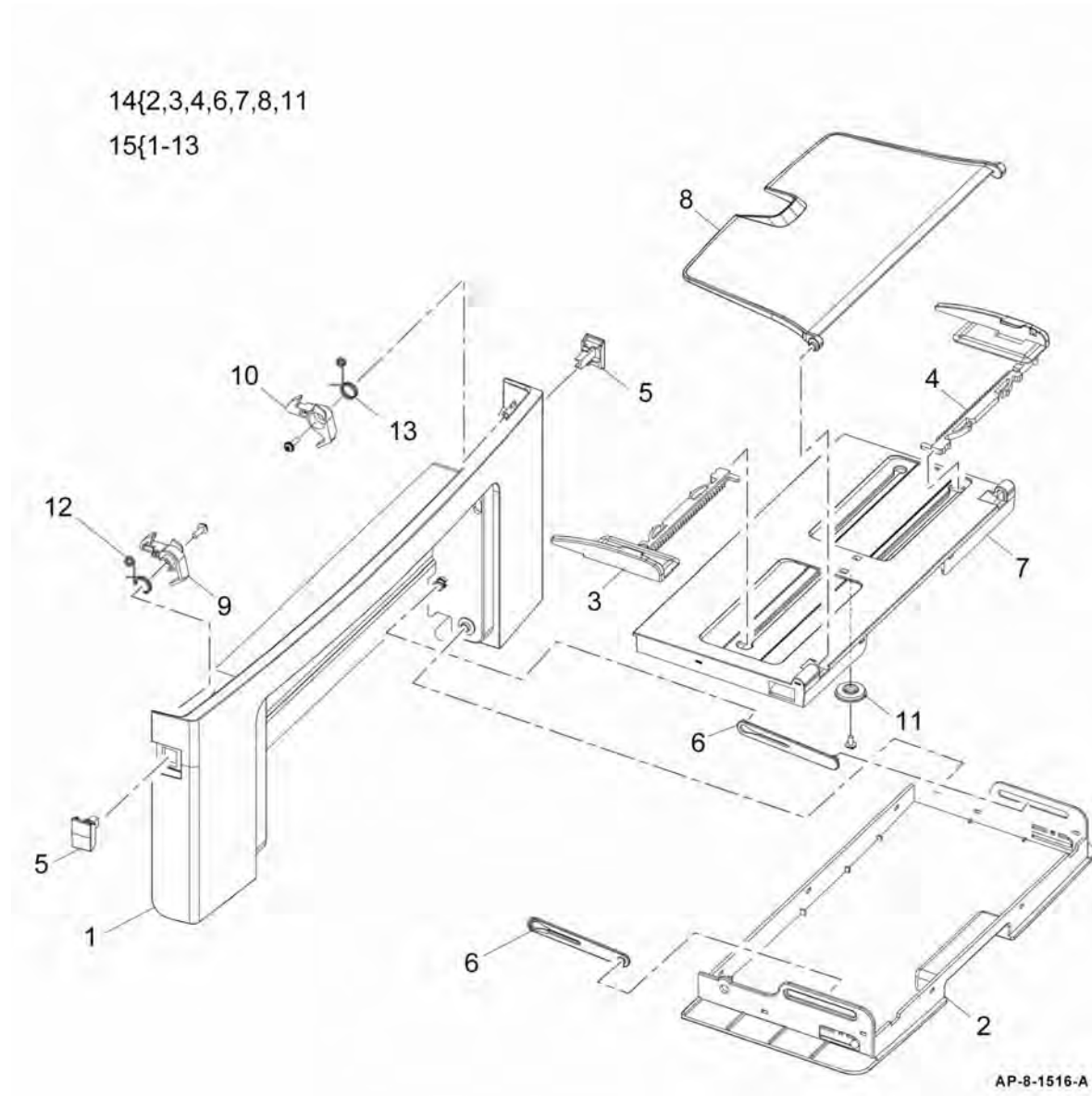

PL 8.10 Paper Tray

Item	Part	Description
1	050N00518	Paper tray (Complete)
2	-	Tray empty indicator (P/O PL 8.10 Item 1)
3	-	Right width paper guide (P/O PL 8.10 Item 1)
4	-	Right width paper guide lock assembly (P/O PL 8.10 Item 1)
5	-	Right tray down lever (P/O PL 8.10 Item 1)
6	-	Tray down lever spring (P/O PL 8.10 Item 1)
7	-	Tray frame (P/O PL 8.10 Item 1)
8	-	Paper length guide spring (P/O PL 8.10 Item 1)
9	-	Paper length guide (P/O PL 8.10 Item 1)
10	-	Paper length guide lower lock (P/O PL 8.10 Item 1)
11	-	Paper length guide spring (P/O PL 8.10 Item 1)
12	-	Paper length guide upper lock (P/O PL 8.10 Item 1)
13	-	Tray extension (P/O PL 8.10 Item 1)
14	-	Tray extension bracket (P/O PL 8.10 Item 1)
15	-	Left tray down lever spring (P/O PL 8.10 Item 1)
16	-	Lift plate actuator spring (P/O PL 8.10 Item 1)
17	-	Pinion gear (P/O PL 8.10 Item 1)
18	-	Left width paper guide (P/O PL 8.10 Item 1)
19	-	Lift plate actuator (P/O PL 8.10 Item 1)
20	019N00947	Retard pad assembly
21	-	Retard pad holder spring (P/O PL 8.10 Item 1)
22	-	Retard pad holder housing (P/O PL 8.10 Item 1)
23	-	Ground strip (P/O PL 8.10 Item 1)
24	-	Paper exit frame (P/O PL 8.10 Item 1)
25	055N00297	Lead edge guide
26	009N01604	Lead edge guide spring
27	-	Lift plate spring (P/O PL 8.10 Item 1)
28	-	Lift plate (P/O PL 8.10 Item 1)
29	-	Pad (P/O PL 8.10 Item 1)
30	-	Label (P/O PL 8.10 Item 1)
31	-	Front cover (P/O PL 8.10 Item 1)

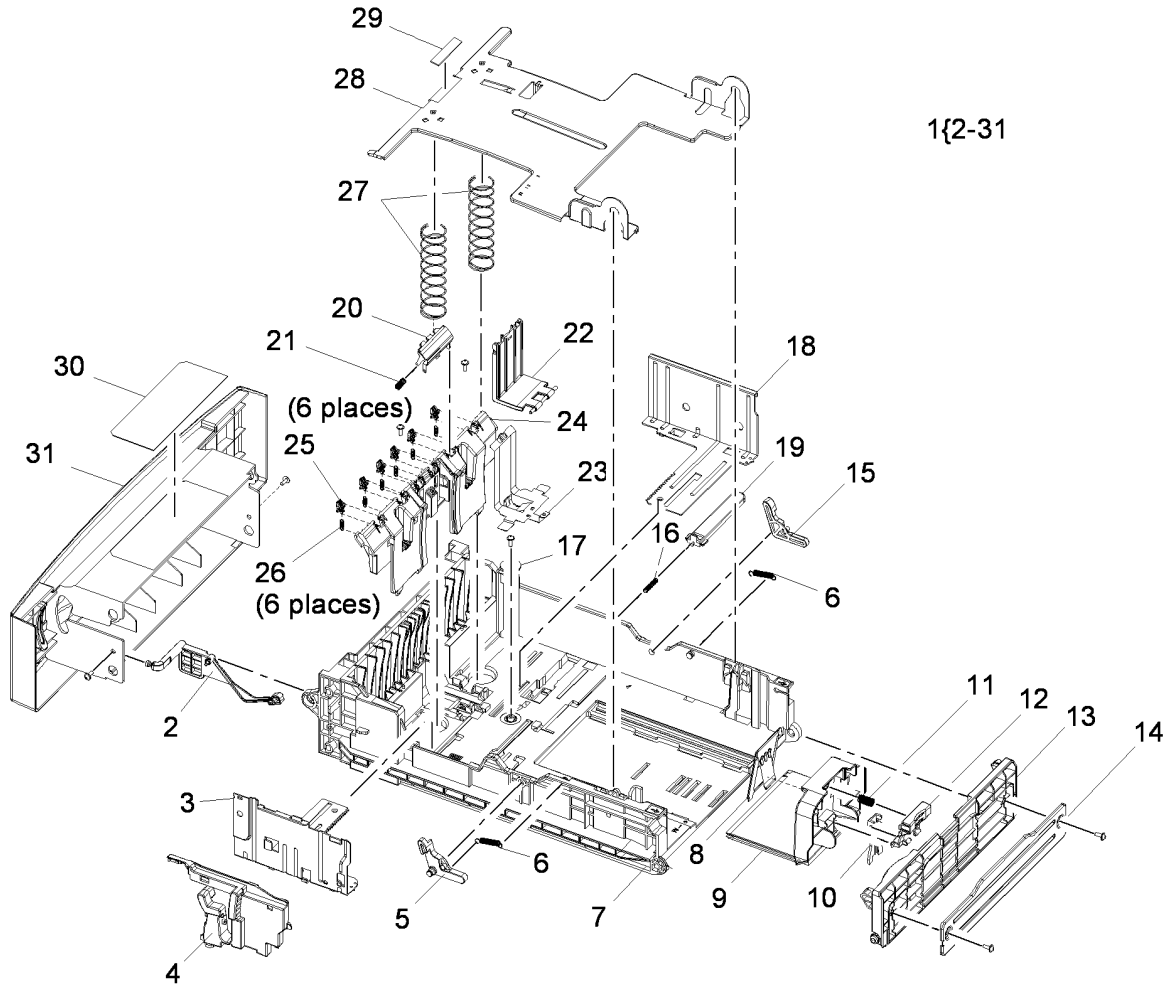

AP-8-1514-A

PL 8.15 Tray 2 Assembly (1 of 2)

Item	Part	Description
1	-	Front cover (P/O PL 8.15 Item 1)
2	-	Bottom cross bar (P/O PL 8.15 Item 1)
3	-	Feed roll idler (P/O PL 8.15 Item 1)
4	-	Feed roll idler spring (P/O PL 8.15 Item 1)
5	-	Left cover (P/O PL 8.15 Item 1)
6	-	Left lower noise insulation (P/O PL 8.15 Item 1)
7	-	Left cover noise insulation (P/O PL 8.15 Item 1)
8	-	Ground strip (P/O PL 8.15 Item 1)
9	-	Tray 2 connector (P/O PL 8.15 Item 1)
10	-	Tray 2 connector holder (P/O PL 8.15 Item 1)
11	-	Tray 2 paper empty sensor cover (P/O PL 8.15 Item 1)
12	-	Rear noise insulation cover (P/O PL 8.15 Item 1)
13	-	Rear noise insulation (P/O PL 8.15 Item 1)
14	-	Rear cover (P/O PL 8.15 Item 1)
15	-	Catch (P/O PL 8.15 Item 1)
16	-	Right cover (P/O PL 8.15 Item 1)
17	-	Right lower noise insulation (P/O PL 8.15 Item 1)
18	-	Idler gear 1 (P/O PL 8.15 Item 27)
19	-	Idler gear clip (P/O PL 8.15 Item 27)
20	-	Drive assembly bracket (P/O PL 8.15 Item 27)
21	-	Idler gear 2 (P/O PL 8.15 Item 27)
22	-	Idler gear 3 (P/O PL 8.15 Item 27)
23	-	Tray 2 feed motor (MOT07-210) (P/O PL 8.15 Item 27) (REP 7.4)
24	-	Tray 2 feed motor bracket (P/O PL 8.15 Item 27)
25	-	Idler gear 4 (P/O PL 8.15 Item 27)
26	-	Idler gear 5 (P/O PL 8.15 Item 27)
27	127N07563	Tray 2 drive assembly
28	050N00519	Tray 2 assembly (Complete)

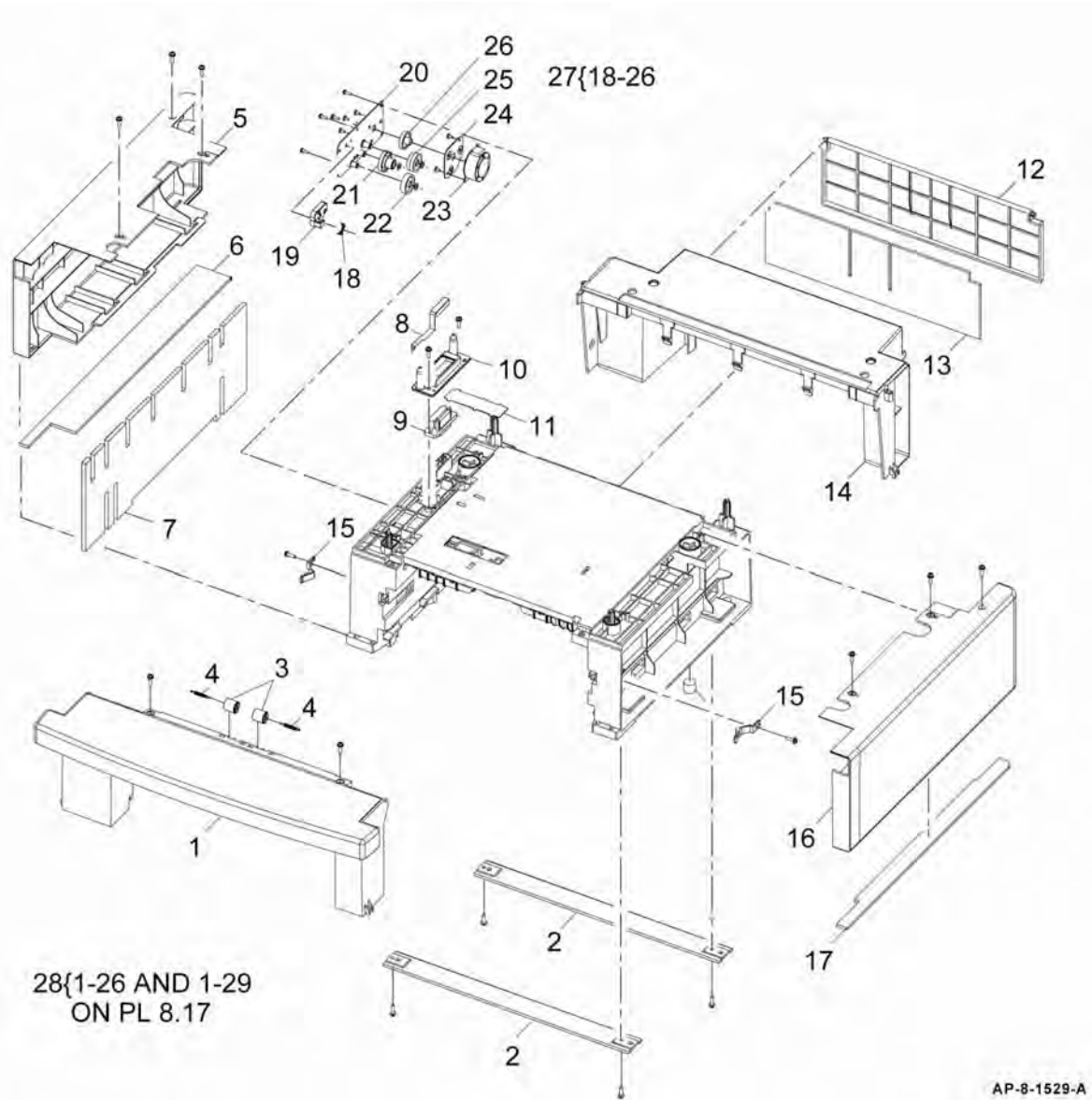

PL 8.17 Tray 2 Assembly (2 of 2)

Item	Part	Description
1	130N01274	Tray 2 paper empty sensor (Q07-210)
2	-	Tray 2 paper empty sensor actuator (P/O PL 8.15 Item 28)
3	-	Static eliminator fixing (P/O PL 8.15 Item 28)
4	-	Left underside cover (P/O PL 8.15 Item 28)
5	-	Right underside cover (P/O PL 8.15 Item 28)
6	-	Pickup idler (P/O PL 8.17 Item 31)
7	-	Pickup rubber (P/O PL 8.17 Item 31)
8	-	Pickup roll shaft (P/O PL 8.15 Item 28)
9	-	Static eliminator (P/O PL 8.15 Item 28)
10	-	Pickup roll (P/O PL 8.17 Item 31)
11	-	Feed roll holder (P/O PL 8.15 Item 28)
12	-	Feed roll (P/O PL 8.15 Item 28)
13	-	KL-clip (P/O PL 8.15 Item 28)
14	-	Bearing (P/O PL 8.15 Item 28)
15	-	Pickup roll cam (P/O PL 8.15 Item 28)
16	-	Ground strip (P/O PL 8.15 Item 28)
17	-	Feed shaft (P/O PL 8.15 Item 28)
18	-	Feed gear (P/O PL 8.15 Item 28)
19	-	Snap on washer (P/O PL 8.15 Item 28)
20	-	Outer pickup gear spring (P/O PL 8.17 Item 30)
21	-	Pickup cam spring (P/O PL 8.15 Item 28)
22	-	Outer pickup gear (P/O PL 8.17 Item 30)
23	-	Inner pickup gear (P/O PL 8.17 Item 30)
24	121N01164	Tray 2 pickup solenoid (SOL08-820) (REP 7.4)
25	140N63300	Tray 2 PWB
26	-	PWB cover (P/O PL 8.15 Item 28)
27	-	Pickup cam (P/O PL 8.15 Item 28)
28	-	Pick up gear core (P/O PL 8.15 Item 28)
29	152N11752	Tray 2 harness
30	007N01593	Clutch assembly
31	022N02345	Pickup roll assembly (NOTE)

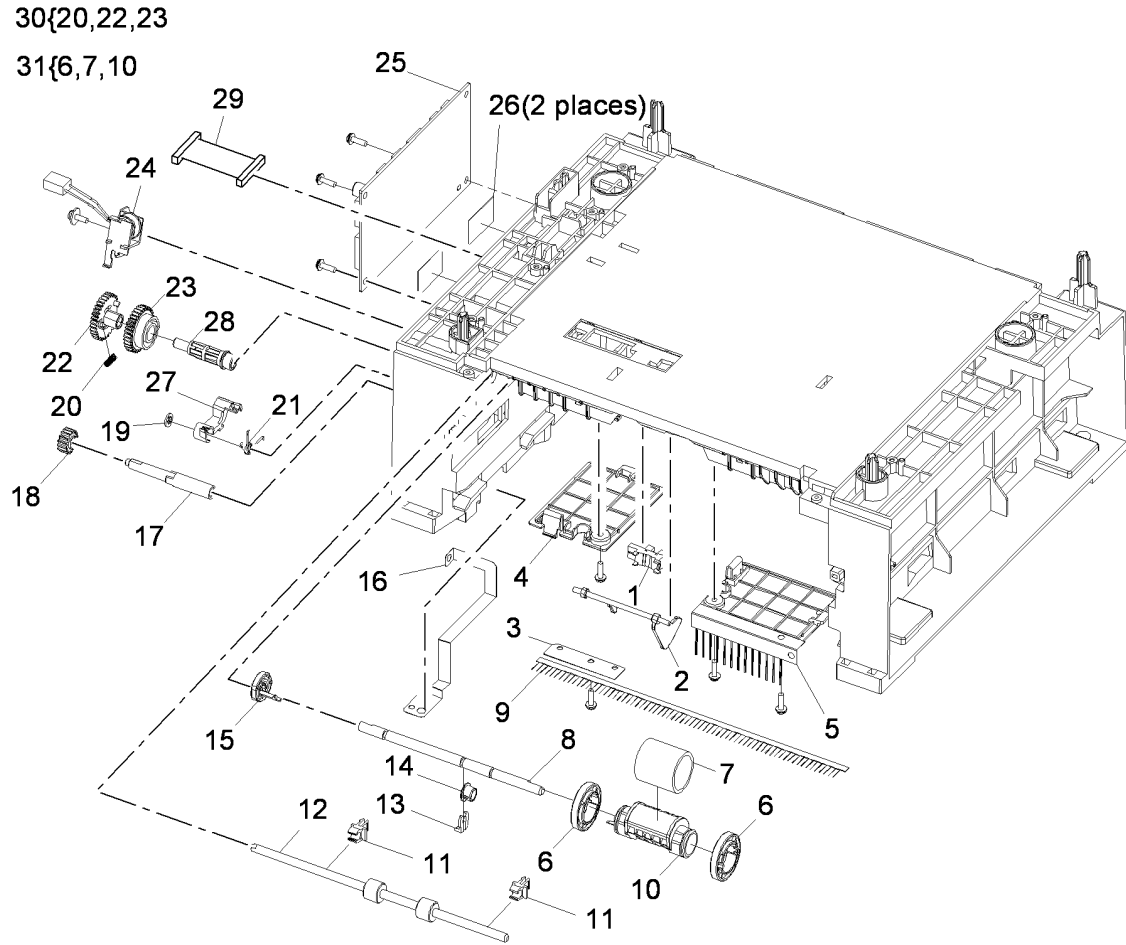

AP-8-1515-A

NOTE: HFSI. To reset the HSFI count go to GP 16.

PL 8.20 Rear Cover Assembly

Item	Part	Description
1	-	Magnet (P/O PL 8.20 Item 11)
2	-	Rear cover (P/O PL 8.20 Item 11)
3	-	Sub panel cover (P/O PL 8.20 Item 11)
4	-	Magnet catch (P/O PL 8.20 Item 11)
5	-	Face up cover (P/O PL 8.20 Item 11)
6	-	Label (P/O PL 8.20 Item 11)
7	-	Fuser output guide (P/O PL 8.20 Item 11)
8	-	Rear stacker (P/O PL 8.20 Item 11)
9	-	Duplex gate (P/O PL 8.20 Item 11)
10	-	Idler (P/O PL 8.20 Item 11)
11	002N02716	Rear cover assembly (Complete)

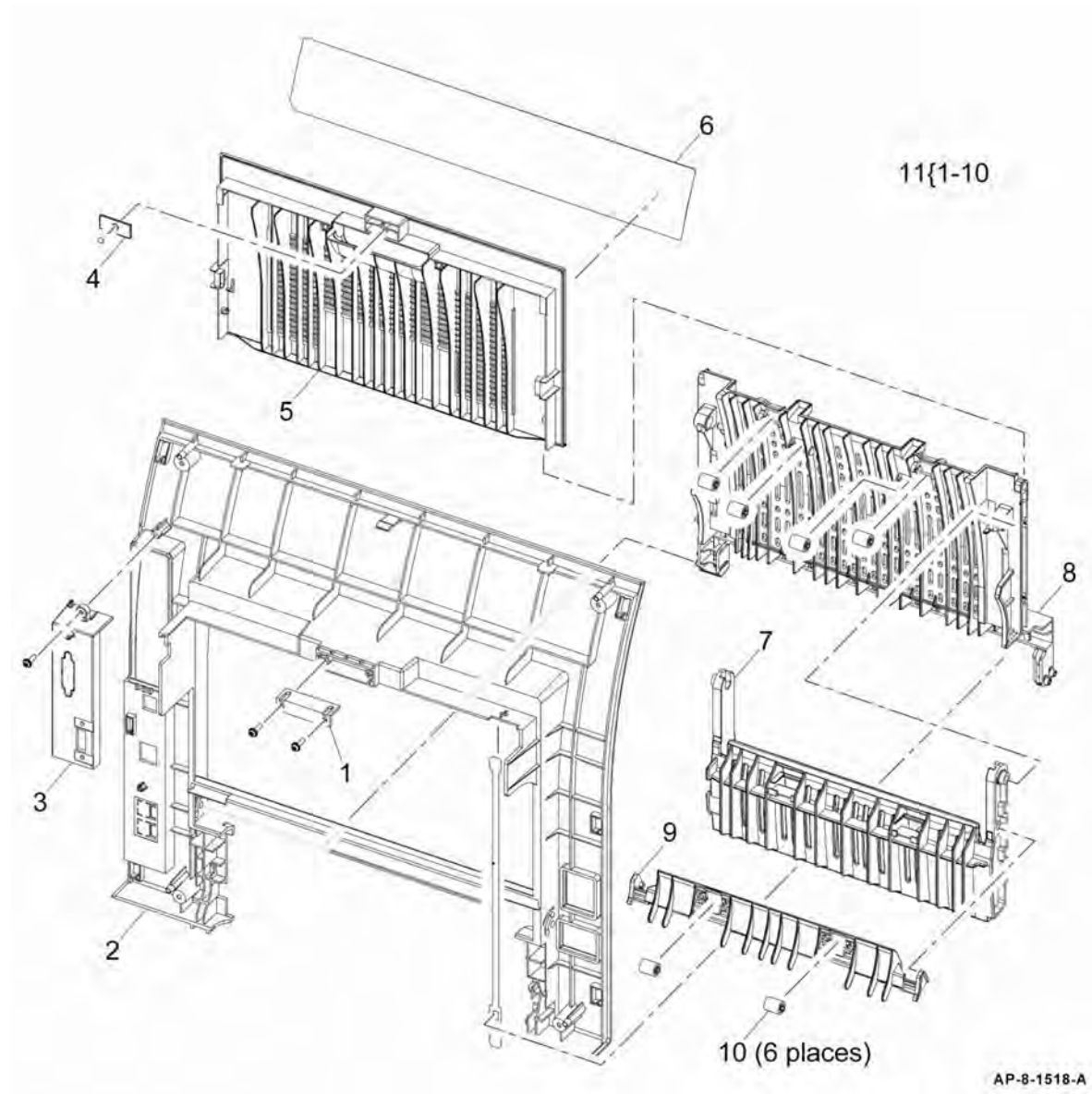

PL 8.25 Registration Rolls

Item	Part	Description
1	-	Grounding plate (Not Spared)
2	-	Grounding plate block (Not Spared)
3	-	Registration roll (Not Spared)
4	-	Feed roll holder (Not Spared)
5	-	Rear feed roll holder (Not Spared)
6	-	Front feed roll holder (Not Spared)
7	-	Feed roll spring (Not Spared)
8	-	Idler roll securing bracket (Not Spared)
9	-	Release latch (Not Spared)
10	-	Ground strip (Not Spared)
11	-	Feed sensor actuator (Not Spared)
12	-	Feed sensor actuator housing (Not Spared)
13	-	Duplex jam 1 sensor actuator (Not Spared)
14	-	Registration sensor actuator (Not Spared)
15	-	Actuator spring (Not Spared)
16	-	Actuator housing (Not Spared)
17	-	Registration roll idler (Not Spared)
18	121N01162	Registration solenoid (SOL08-850) (REP 7.2)
19	121N01163	Tray 1 pickup solenoid (SOL08-810) (REP 7.2)
20	-	Feed bracket (Not Spared)
21	005N01031	Registration roll clutch (REP 8.1)
22	-	Tray 2 connector (Not Spared)
23	-	Thermistor 2 (Not Spared) (NOTE)

NOTE: Shown for reference only. For future use.

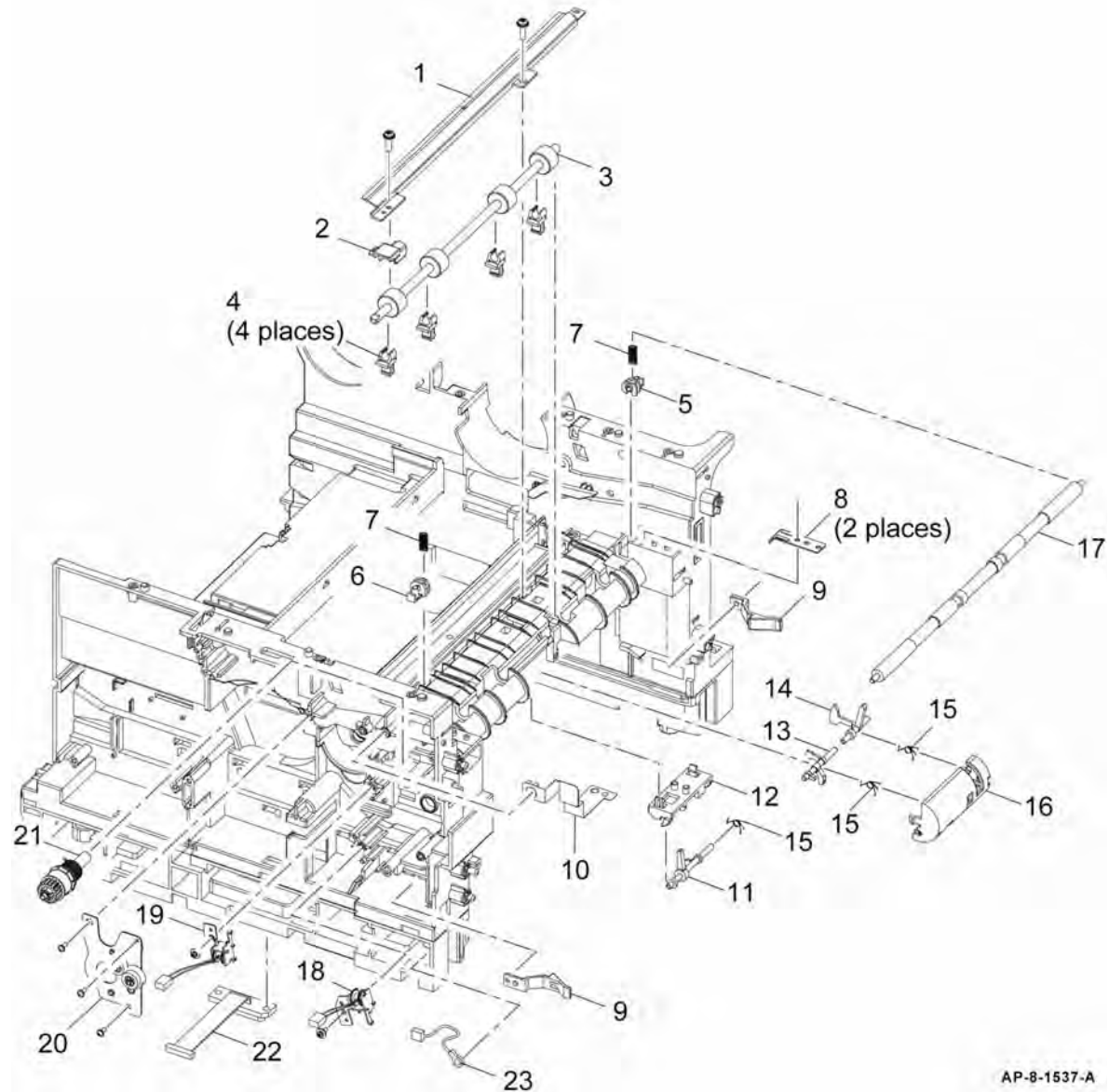

AP-8-1537-A

PL 9.10 Print Cartridge

Item	Part	Description
1	–	Print cartridge (Not Spared) (NOTE)
2	002N02628	Transfer roll (NOTE)
3	–	Spring contacts (Not Spared)
4	–	Print cartridge power strip (Supply, DEV, OPC) (Not Spared)
5	–	Print cartridge power strip (MHV) (Not Spared)
6	–	Terminal cover (Not Spared) (REP 9.1)
7	140N63302	CRUM PWB

NOTE: HFSI. To reset the HSF1 count go to GP 16.

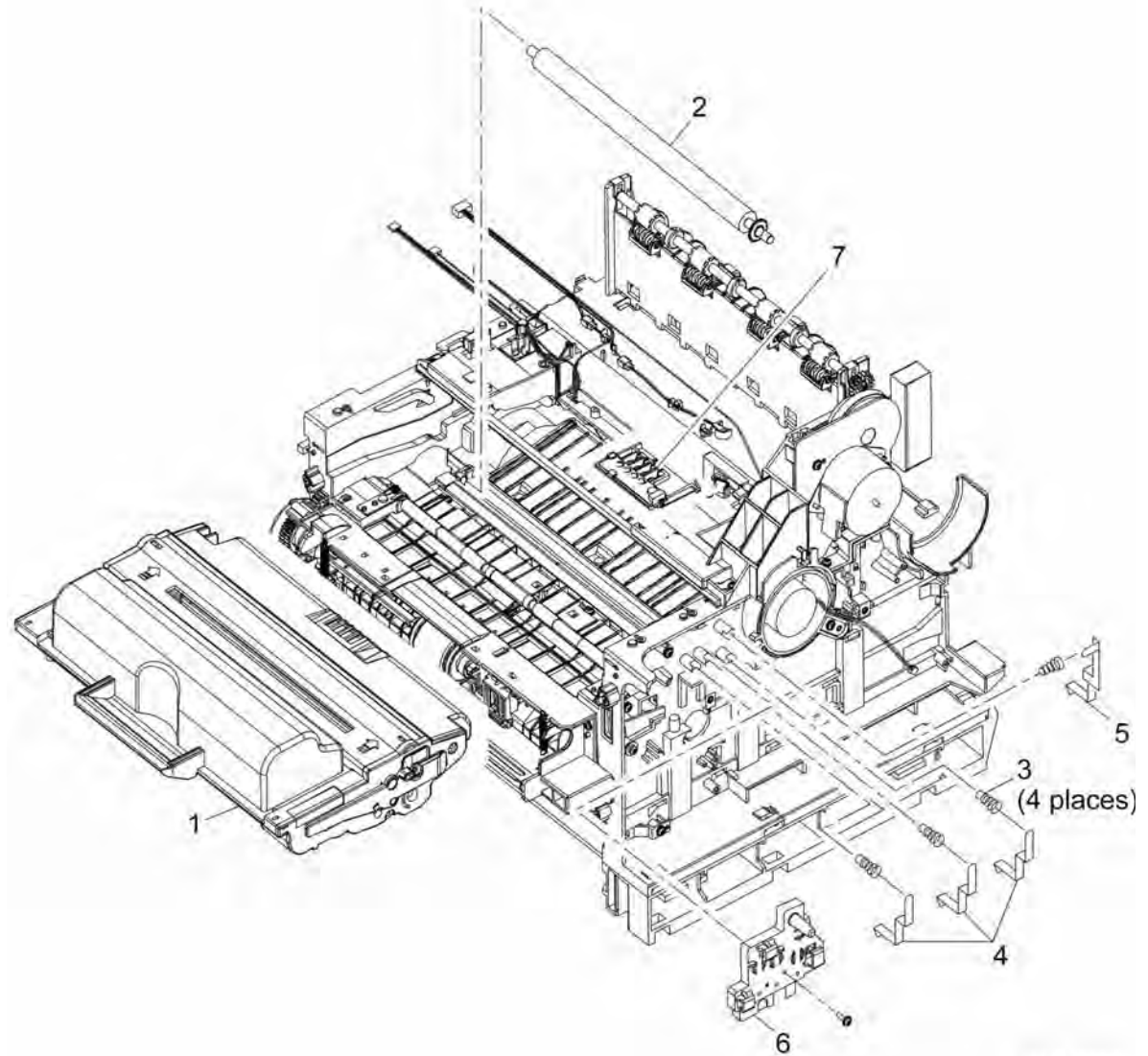

AP-8-1534-A

PL 10.10 Fuser Assembly (1 of 3)

Item	Part	Description
1	126N00290	Fuser assembly (220V) (REF: PL 10.12, PL 10.15) (NOTE)
-	126N00291	Fuser assembly (110V) (REF: PL 10.12, PL 10.15) (NOTE)

NOTE: HFSI. To reset the HSF1 count go to GP 16.

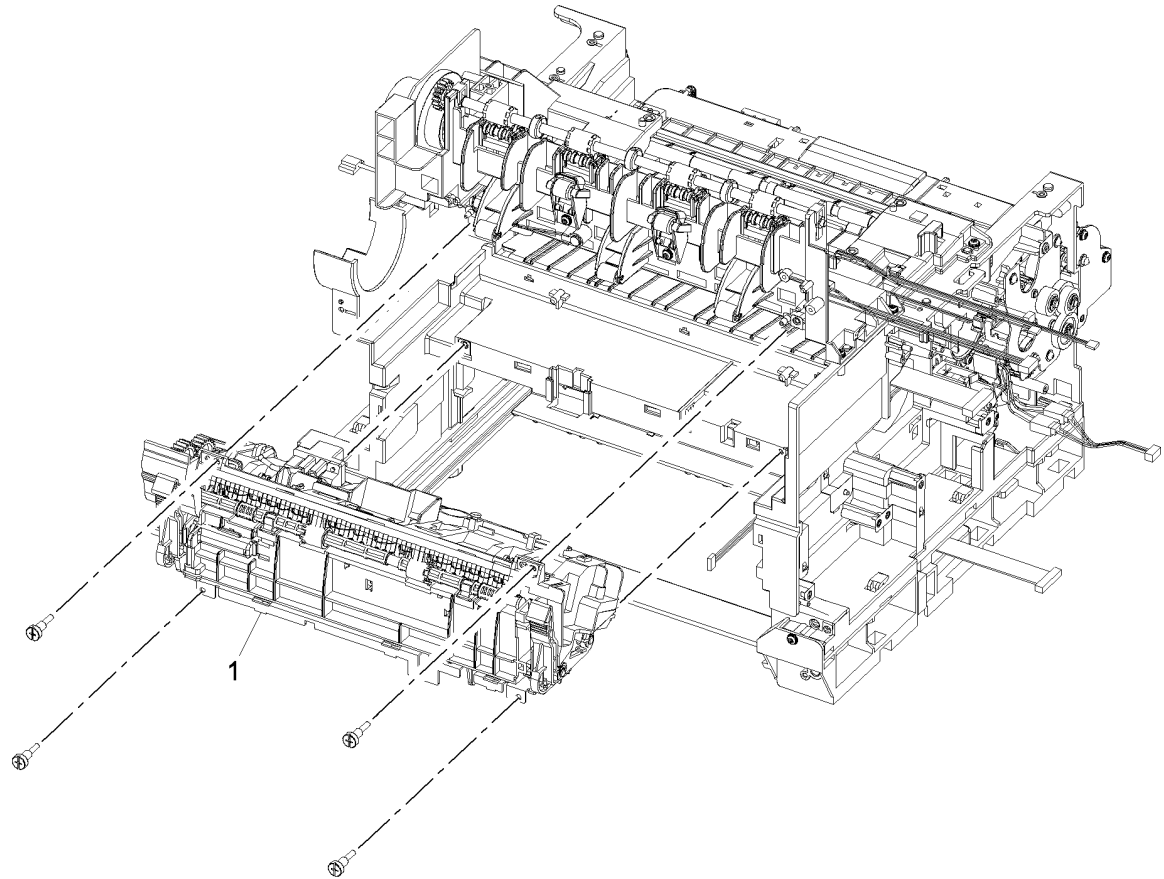

AP-8-1536-A

PL 10.12 Fuser Assembly (2 of 3)

Item	Part	Description
1	-	Upper cover (P/O PL 10.10 Item 1)
2	-	Left lamp cap (P/O PL 10.10 Item 1)
3	-	Right lamp cap (P/O PL 10.10 Item 1)
4	-	Stripper finger spring (P/O PL 10.10 Item 1)
5	-	Static eliminator (P/O PL 10.10 Item 1)
6	-	Fuser exit roll (P/O PL 10.10 Item 1)
7	-	Exit gear (P/O PL 10.10 Item 1)
8	-	Exit roll holder (P/O PL 10.12 Item 19)
9	-	Fuser exit sensor actuator (P/O PL 10.12 Item 19)
10	-	Release latch (P/O PL 10.12 Item 19)
11	-	Release latch spring (P/O PL 10.12 Item 19)
12	-	Fuser door (P/O PL 10.12 Item 19)
13	-	Stripper finger (P/O PL 10.10 Item 1)
14	-	Ground strip (P/O PL 10.10 Item 1)
15	-	Fuser connector (P/O PL 10.10 Item 1)
16	130N01489	Thermistor
17	-	Idler (P/O PL 10.10 Item 1)
18	130N01490	Thermostat
19	126N00292	Fuser door (Complete)

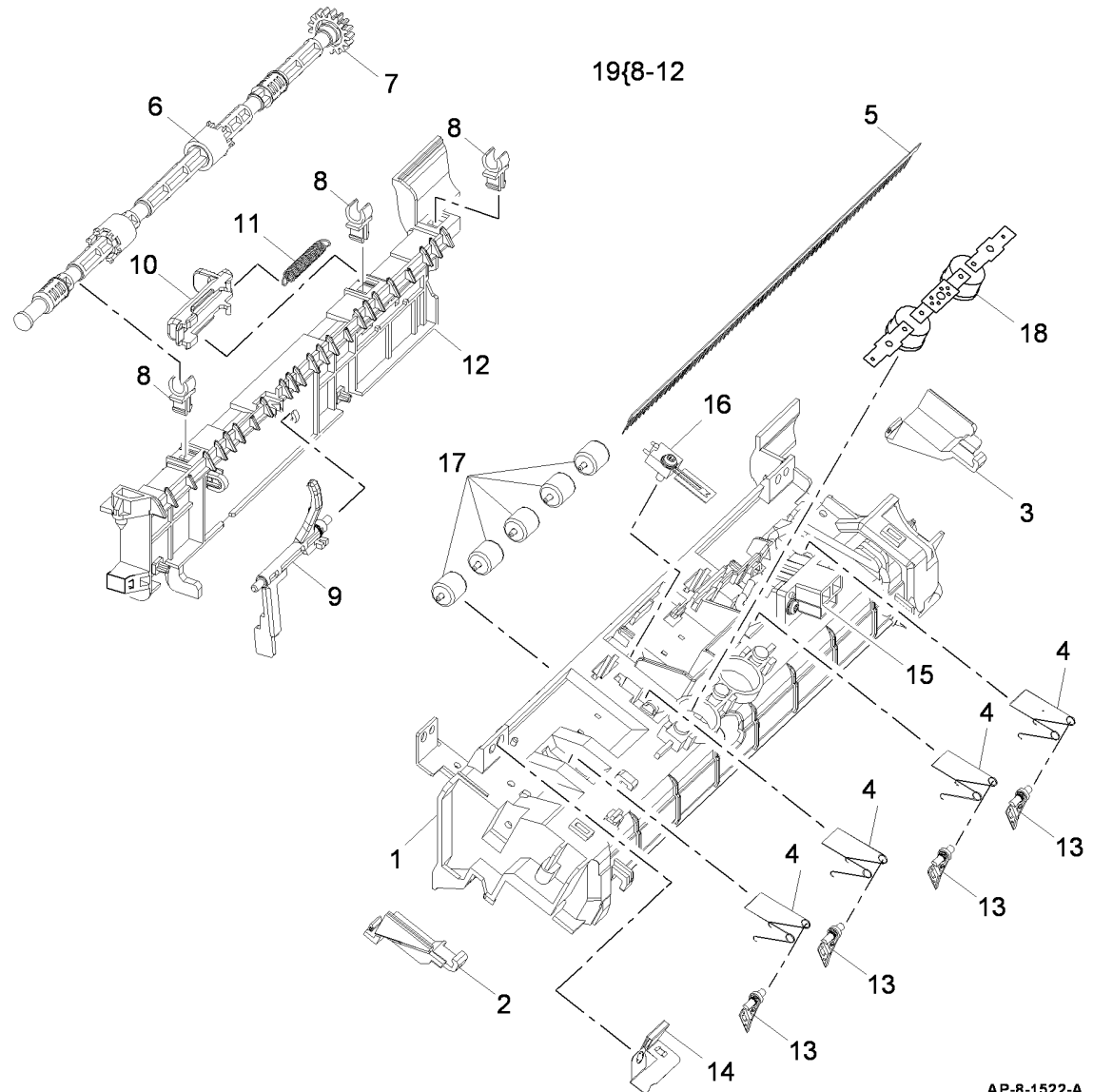

AP-8-1522-A

PL 10.15 Fuser Assembly (3 of 3)

Item	Part	Description
1	-	Heat roll (P/O PL 10.10 Item 1)
2	-	Pressure roll 1 (P/O PL 10.10 Item 1)
3	-	Pressure roll 2 (P/O PL 10.10 Item 1)
4	-	Fuser idler gear (P/O PL 10.10 Item 1)
5	-	Link jam lever (P/O PL 10.10 Item 1)
6	-	Input guide (P/O PL 10.10 Item 1)
7	-	Pressure roll securing block (P/O PL 10.10 Item 1)
8	-	Outer bearing (P/O PL 10.10 Item 1)
9	-	Inner bearing (P/O PL 10.10 Item 1)
10	-	Pressure roll gear bracket (P/O PL 10.10 Item 1)
11	-	Fuser frame (P/O PL 10.10 Item 1)
12	122N00260	Heat lamp (110V) (REP 10.6)
-	122N00261	Heat lamp (220V) (REP 10.6)
13	-	Fuser gear (P/O PL 10.10 Item 1)
14	-	Fuser nip release handle (P/O PL 10.10 Item 1)

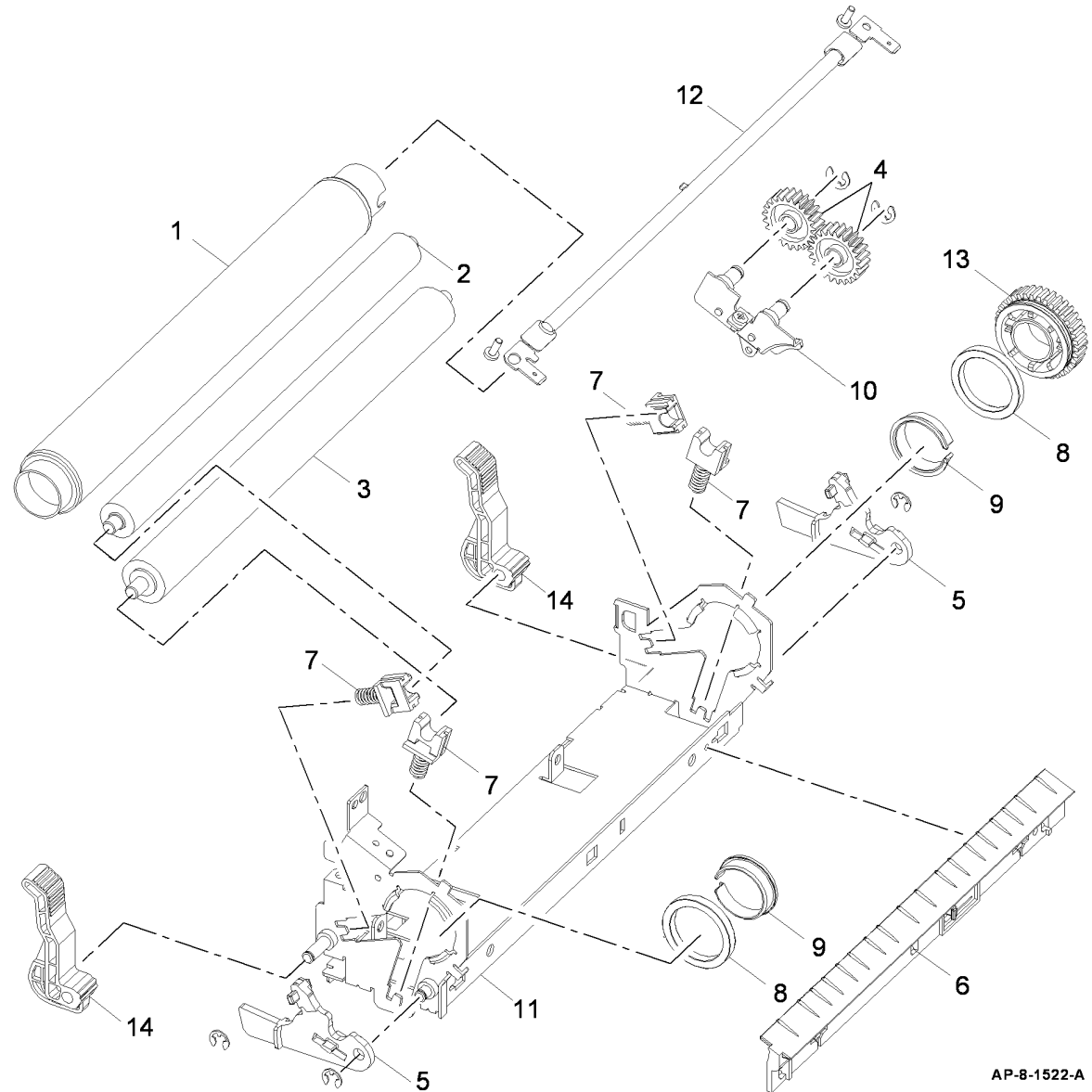

AP-8-1522-A

PL 10.20 Duplex Drive Assembly

Item	Part	Description
1	127N07558	Duplex motor (MOT04-300) (REP 10.1)
2	127N07485	Fuser fan
3	-	Duplex motor bracket (P/O PL 10.20 Item 13)
4	127N07560	Exit motor (MOT04-200) (REP 10.2)
5	-	Exit motor bracket (P/O PL 10.20 Item 11)
6	-	Exit motor gear idler (P/O PL 10.20 Item 11)
7	-	Exit motor clutch (P/O PL 10.20 Item 11)
8	-	Exit motor clutch gear (P/O PL 10.20 Item 11)
9	-	Fuser connection gear (P/O PL 10.20 Item 11)
10	-	Exit motor intermediate gear (P/O PL 10.20 Item 11)
11	007N01594	Exit drive assembly (REP 10.2)
12	-	Duplex drive gear (P/O PL 10.20 Item 13)
13	007N01592	Duplex drive assembly (REP 10.1)

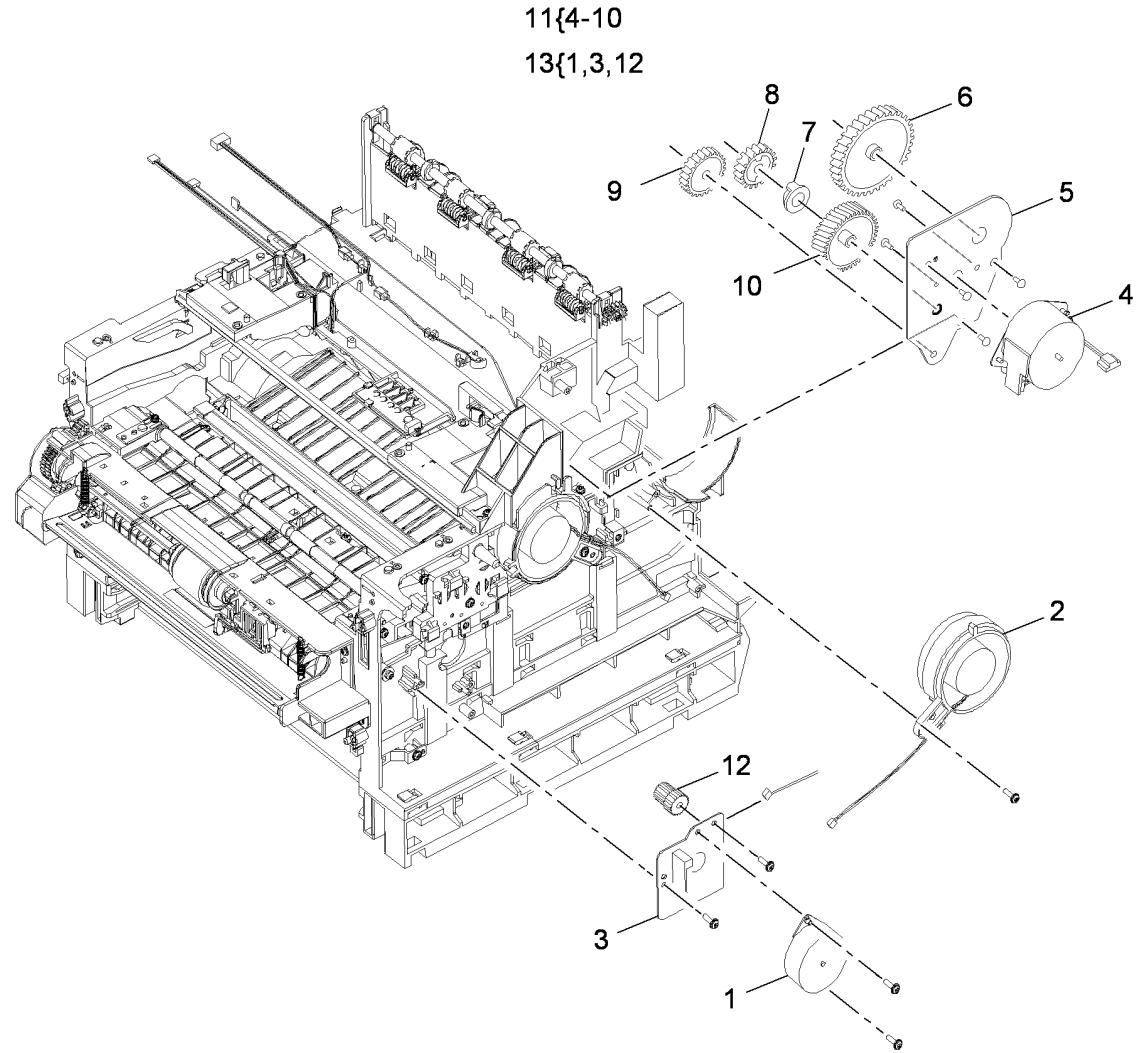

AP-8-1510-A

PL 10.22 Front Duplex Guide Assembly

Item	Part	Description
1	130N01274	Tray 1 paper empty sensor (Q07-110)
2	-	KL-clip (P/O PL 10.22 Item 15)
3	-	Front duplex guide (P/O PL 10.22 Item 15)
4	-	Sheet guide (P/O PL 10.22 Item 15)
5	-	Static eliminator (P/O PL 10.22 Item 15)
6	-	Duplex assembly clamp (P/O PL 10.22 Item 15)
7	-	Cam (P/O PL 10.22 Item 15)
8	-	Pickup shaft (P/O PL 10.22 Item 15)
9	-	Feed roll (P/O PL 10.22 Item 15)
10	-	Tray 1 paper empty sensor actuator (P/O PL 10.22 Item 15)
11	-	Static eliminator (P/O PL 10.22 Item 15)
12	-	Feed roll holder (P/O PL 10.22 Item 15)
13	-	Bearing (P/O PL 10.22 Item 15)
14	022N02343	Tray 1 pickup roll (NOTE)
15	032N00490	Front duplex guide assembly (Complete) (REP 10.3)

NOTE: HFSI. To reset the HFSI count go to GP 16.

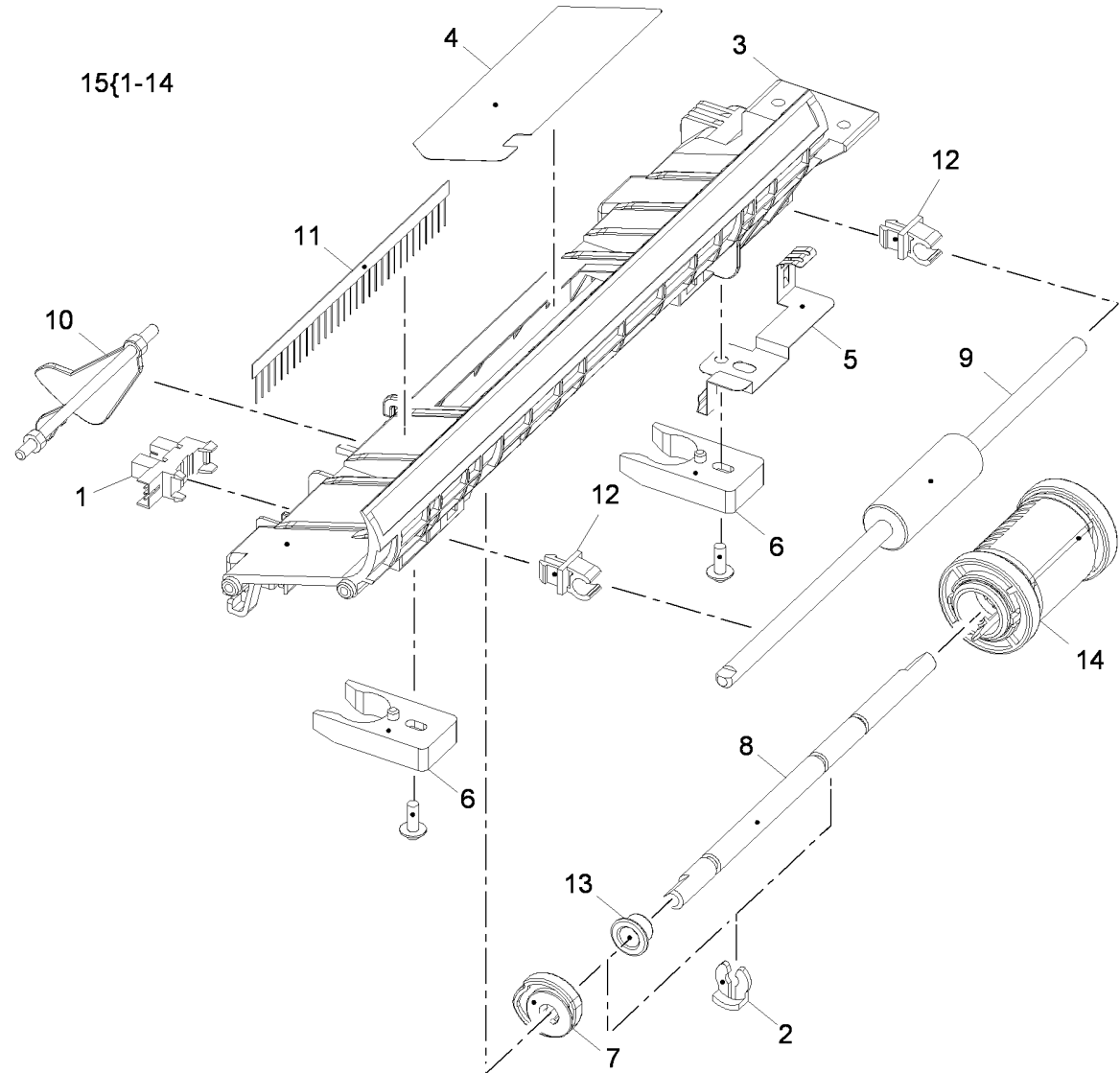

AP-8-1520-A

PL 10.23 Duplex Assembly (1 of 3)

Item	Part	Description
1	-	Duplex frame (P/O PL 10.23 Item 18)
2	-	Idler spring (P/O PL 10.23 Item 18)
3	-	Bush (P/O PL 10.23 Item 18)
4	-	Upper guide (P/O PL 10.23 Item 18)
5	-	Alignment bracket (P/O PL 10.23 Item 18)
6	-	Spring assembly (P/O PL 10.23 Item 18)
7	-	Exit gear (P/O PL 10.23 Item 18)
8	-	Idler shaft (P/O PL 10.23 Item 18)
9	-	Duplex roll idler (P/O PL 10.23 Item 18)
10	-	Pulley (P/O PL 10.23 Item 18)
11	-	Snap on washer (P/O PL 10.23 Item 18)
12	-	Drive drive belt (P/O PL 10.23 Item 18)
13	-	Rear duplex roll (P/O PL 10.23 Item 18)
14	-	Front duplex roll (P/O PL 10.23 Item 18)
15	-	Static eliminator (P/O PL 10.23 Item 18)
16	-	Noise insulation (P/O PL 10.23 Item 18)
17	-	Noise insulation cover (P/O PL 10.23 Item 18)
18	101N01420	Duplex assembly (Complete)

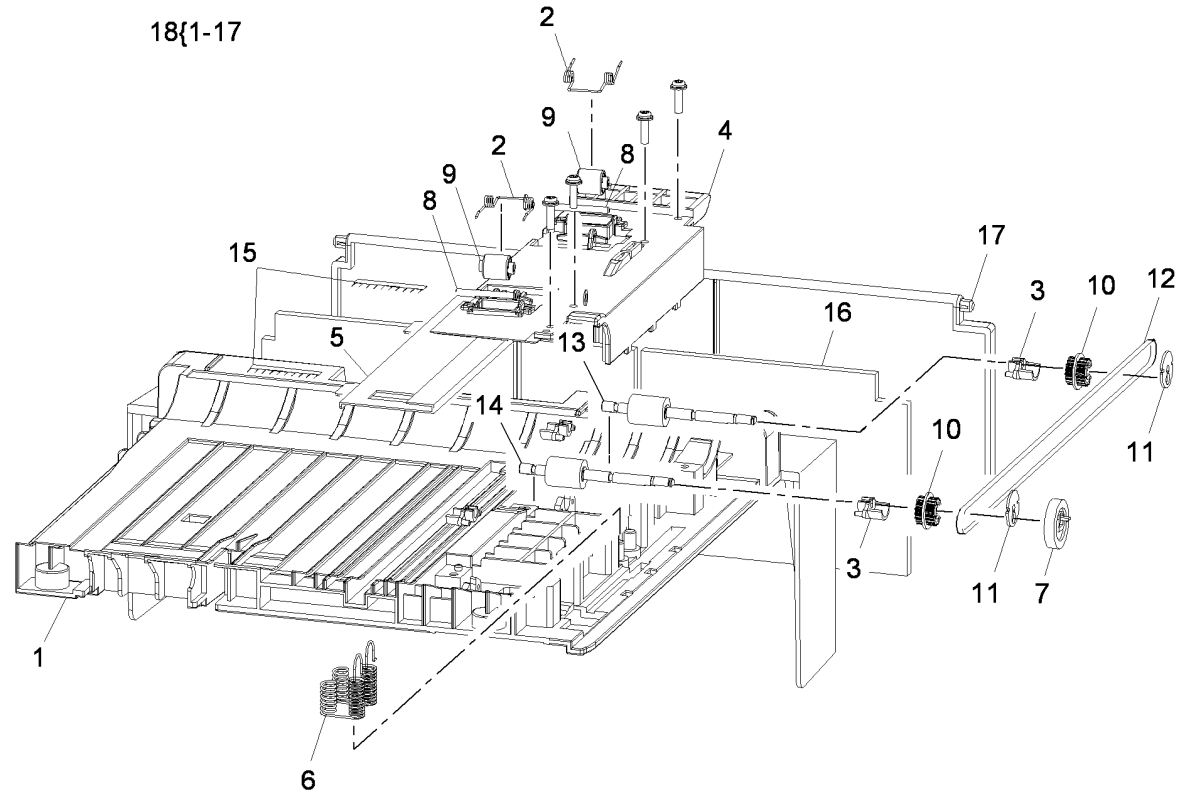

AP-8-1519-A

PL 10.25 Exit Feed Assembly

Item	Part	Description
1	-	Exit idler spring (P/O PL 10.25 Item 21)
2	-	Exit idler holder (P/O PL 10.25 Item 21)
3	-	Primary exit idler (P/O PL 10.25 Item 21)
4	-	Secondary exit idler (P/O PL 10.25 Item 21)
5	-	Thermistor (Not Spared) (NOTE)
6	-	Thermistor harness (Not Spared) (NOTE)
7	-	CRUM PWB (REF: PL 9.10 Item 7)
8	152N11754	Fuser terminal (REP 10.5)
9	-	Ground strip (Not Spared)
10	-	Ground strip (Not Spared)
11	-	LSU support plate (Not Spared)
12	-	Exit roll holder (Not Spared)
13	-	Transport roll idler holder (Not Spared)
14	-	Transport roll idler spring (Not Spared)
15	-	Transport roll idler (Not Spared)
16	-	Transport roll idler shaft (Not Spared)
17	-	Document path idler roll (Not Spared)
18	-	Exit roll gear (Not Spared)
19	-	Main housing (Not Spared)
20	-	Housing spring (Not Spared)
21	130N01531	Idler assembly (REP 10.4)
22	022N02344	Exit roll (REP 10.4)

NOTE: Shown for reference only. For future use.

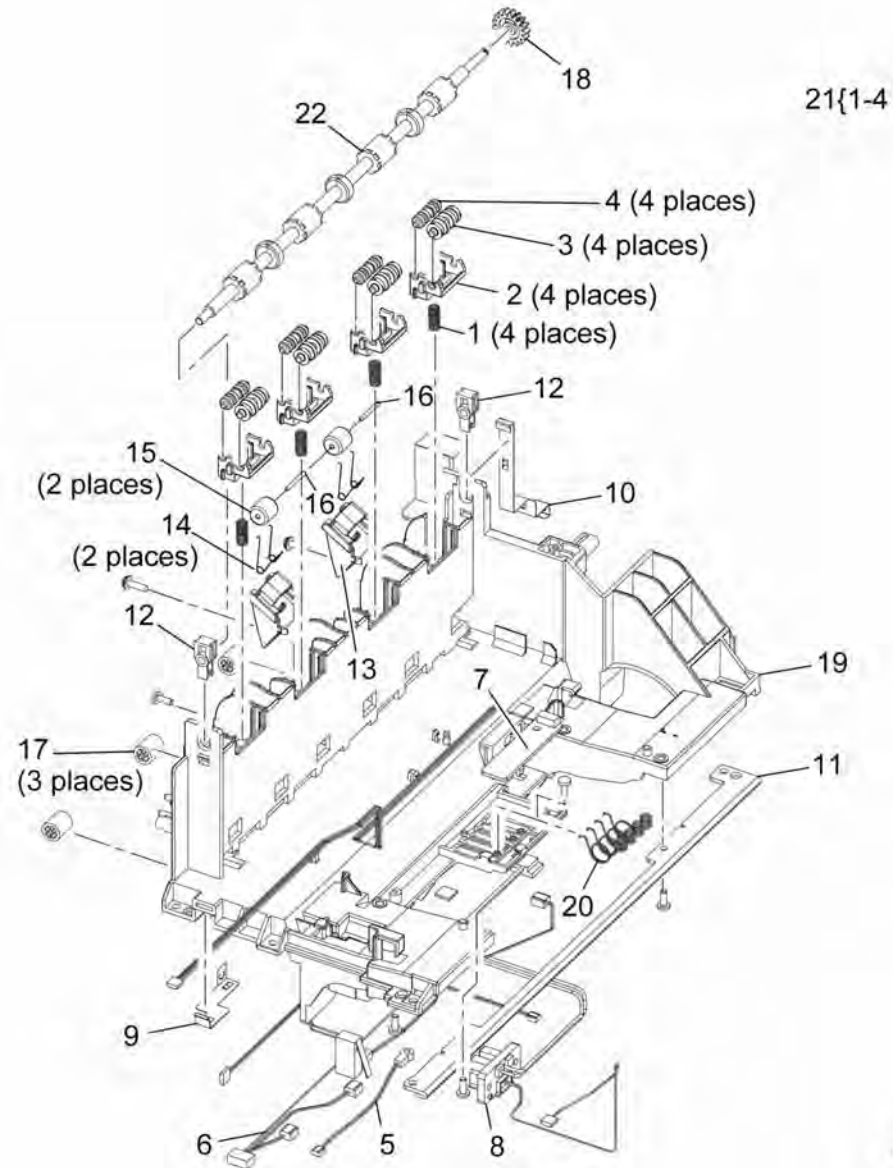

AP-8-1512-A

PL 10.30 Exit Cover Assembly

Item	Part	Description
1	–	Exit cover (P/O PL 10.30 Item 12)
2	130N01274	Out bin full sensor (Q08-720)
3	–	Out bin full sensor harness (P/O PL 10.30 Item 12)
4	120N00517	Out bin full sensor actuator
5	–	Transport roll holder (P/O PL 10.30 Item 12)
6	–	Transport roll (P/O PL 10.30 Item 12)
7	–	Transport roll idler gear (P/O PL 10.30 Item 12)
8	–	Transport roll gear (P/O PL 10.30 Item 12)
9	–	Ground strip (P/O PL 10.30 Item 12)
10	125N00094	Static eliminator
11	–	Damper (P/O PL 10.30 Item 12)
12	002N02714	Exit cover assembly (Complete)

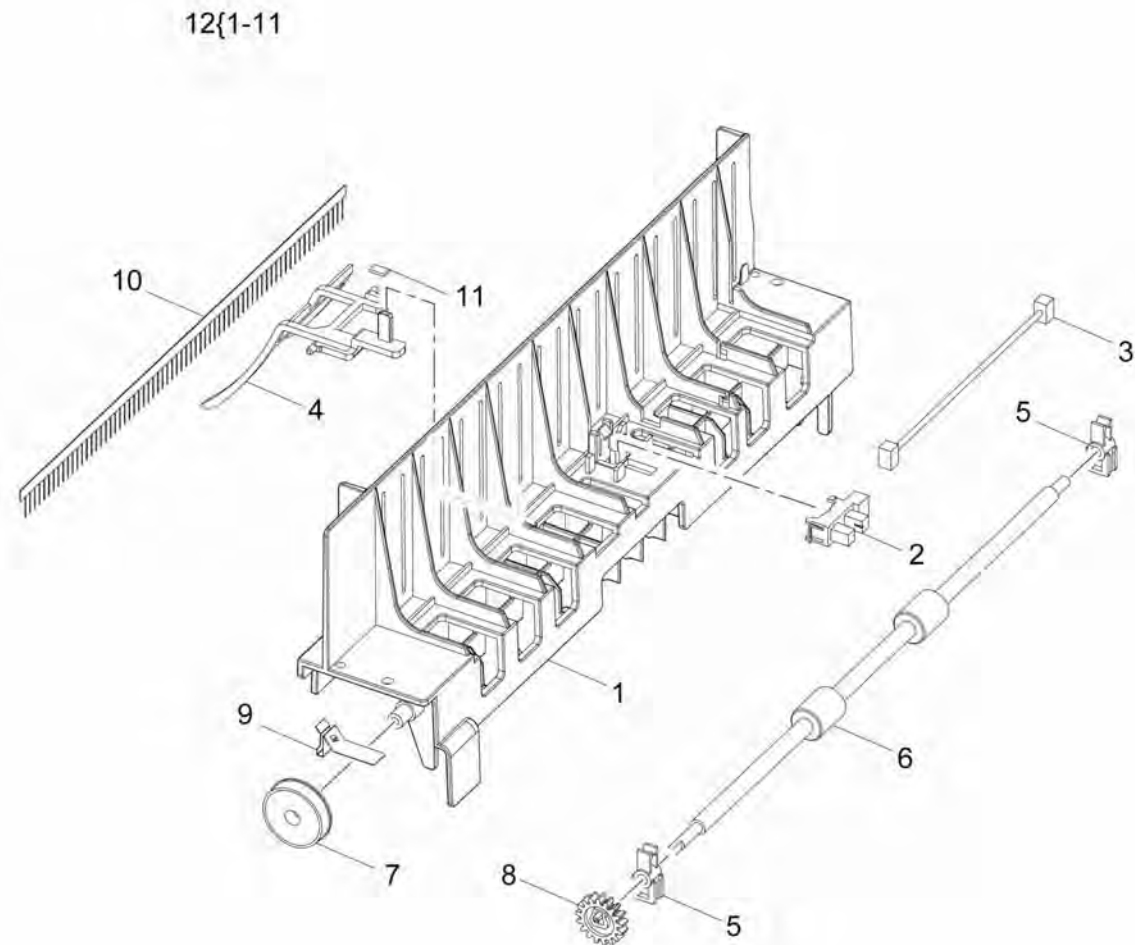

AP-8-1513-A

PL 11.10 Stapler Assembly

Item	Part	Description
1	-	Stapler housing bracket (Not Spared)
2	-	Stapler door interlock switch (Not Spared)
3	029N00395	Stapler
4	-	Stapler assembly (Complete) (Not Spared)
5	-	Stapler harness (Not Spared)

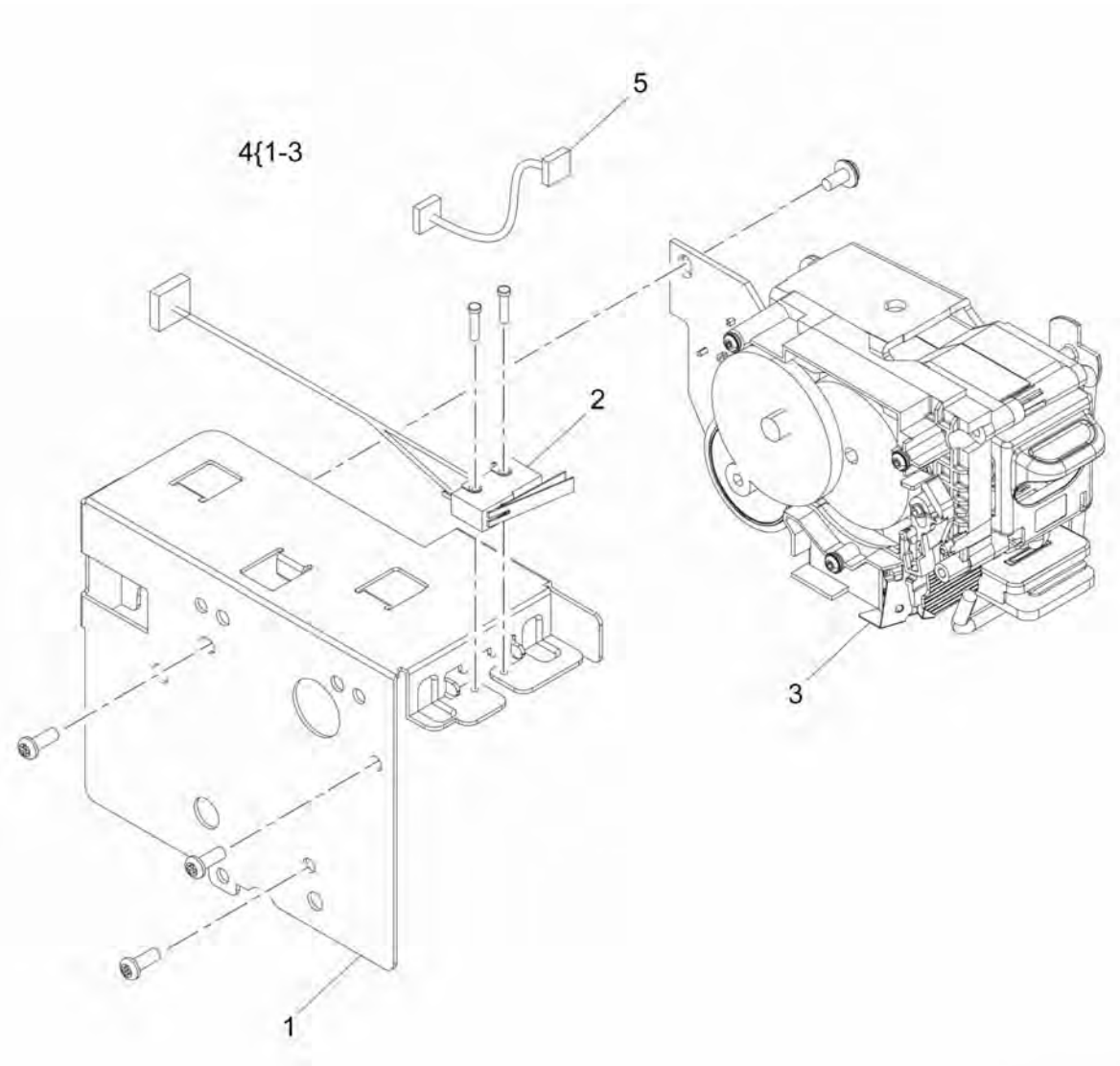

AP-8-1526-A

PL 14.10 Scanner Assembly

Item	Part	Description
1	–	Scanner base (P/O PL 14.10 Item 26)
2	–	UI base (P/O PL 14.10 Item 26)
3	–	LCD support (P/O PL 14.10 Item 26)
4	130N01274	CCD home sensor (A), Platen cover sensor (B) (REP 14.2)
5	–	Ferrite (P/O PL 14.10 Item 26)
6	127N07564	Scan motor drive assembly
7	–	Ground strip (P/O PL 14.10 Item 26)
8	133N23230	CCD module (REP 14.2)
9	–	Ground strip (P/O PL 14.10 Item 26)
10	127N07561	Scan motor
11	–	Platen cover sensor actuator (P/O PL 14.10 Item 26)
12	–	Platen cover sensor actuator spring (P/O PL 14.10 Item 26)
13	152N11750	DADF connector
14	–	Drive belt spring (P/O PL 14.10 Item 26)
15	–	Pulley shaft (P/O PL 14.10 Item 26)
16	–	Pulley (lower) (P/O PL 14.10 Item 26)
17	109N00542	CCD module belt
18	–	Pulley (upper) (P/O PL 14.10 Item 26)
19	–	CCD module guide rail (P/O PL 14.10 Item 26)
20	002N02719	Scanner cover (REP 14.2)
21	–	Scanner lock bracket (P/O PL 14.10 Item 26)
22	–	Scanner lock (P/O PL 14.10 Item 26)
23	117N01788	CCD module cable
24	–	Left trim (P/O PL 14.10 Item 26)
25	–	Right trim (P/O PL 14.10 Item 26)
26	109N00688	Scanner assembly (Complete) (REP 14.1)

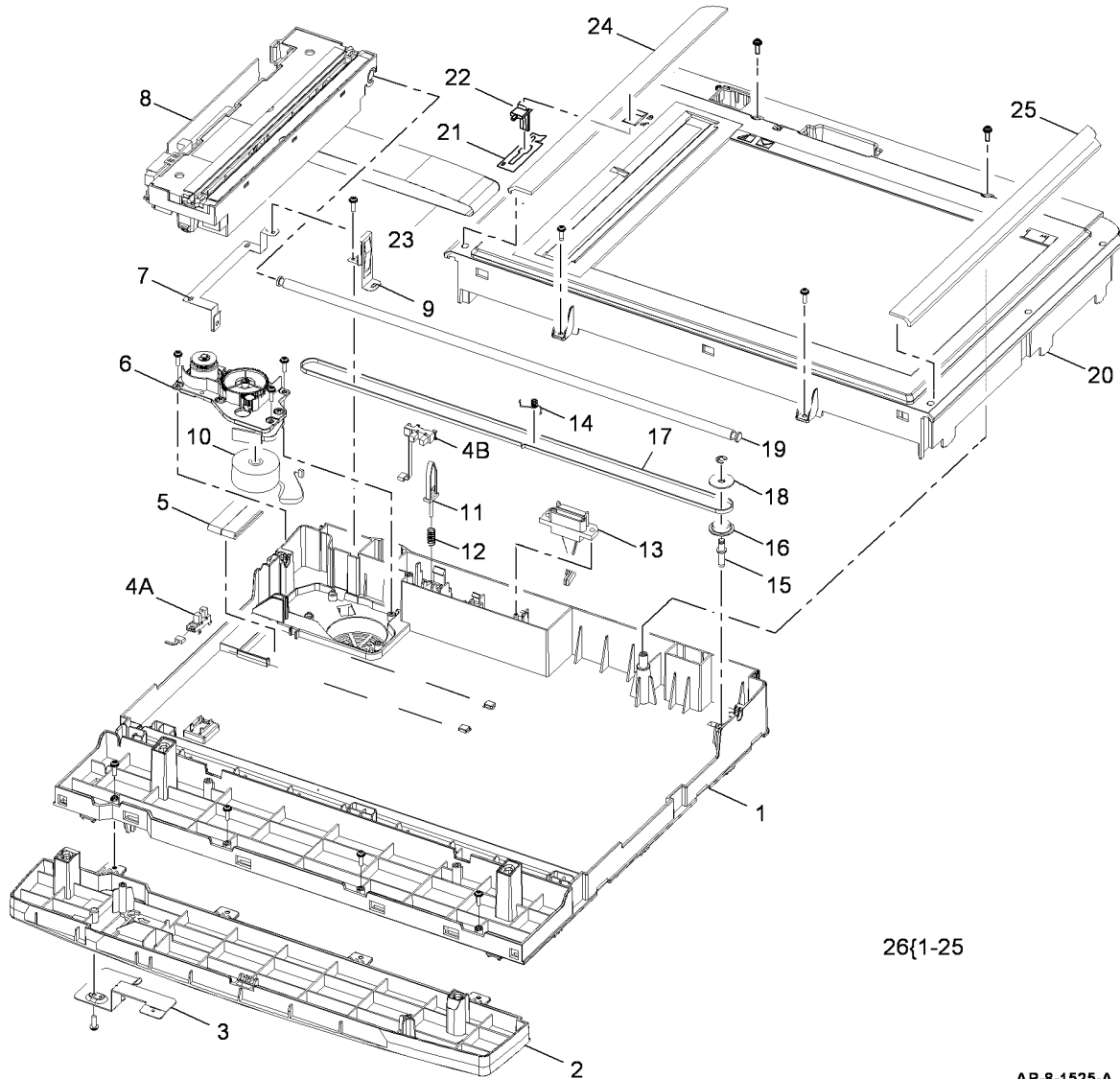

26{1-25

AP-8-1525-A

PL 28.10 Main Covers

Item	Part	Description
1	002N02713	Right cover (REP 28.1)
2	-	Exit cover assembly (REF: PL 10.30 Item 12)
3	-	Out-bin assembly (Not Spared) (REP 28.2)
4	002N02715	Left cover (REP 28.1)
5	-	Rear cover assembly (REF: PL 8.20 Item 11)
6	002N02717	Front mid cover (REP 28.3)
7	-	Front cover assembly (Not Spared)
8	-	Front cover interlock switch actuator (Not Spared)
9	-	Stapler door (Not Spared)
10	-	Main PWB bracket (REF: PL 3.10 Item 9)
11	-	DIMM cover (Not Spared) (REP 28.1)
12	-	Left cover assembly (Not Spared) (REP 28.1)

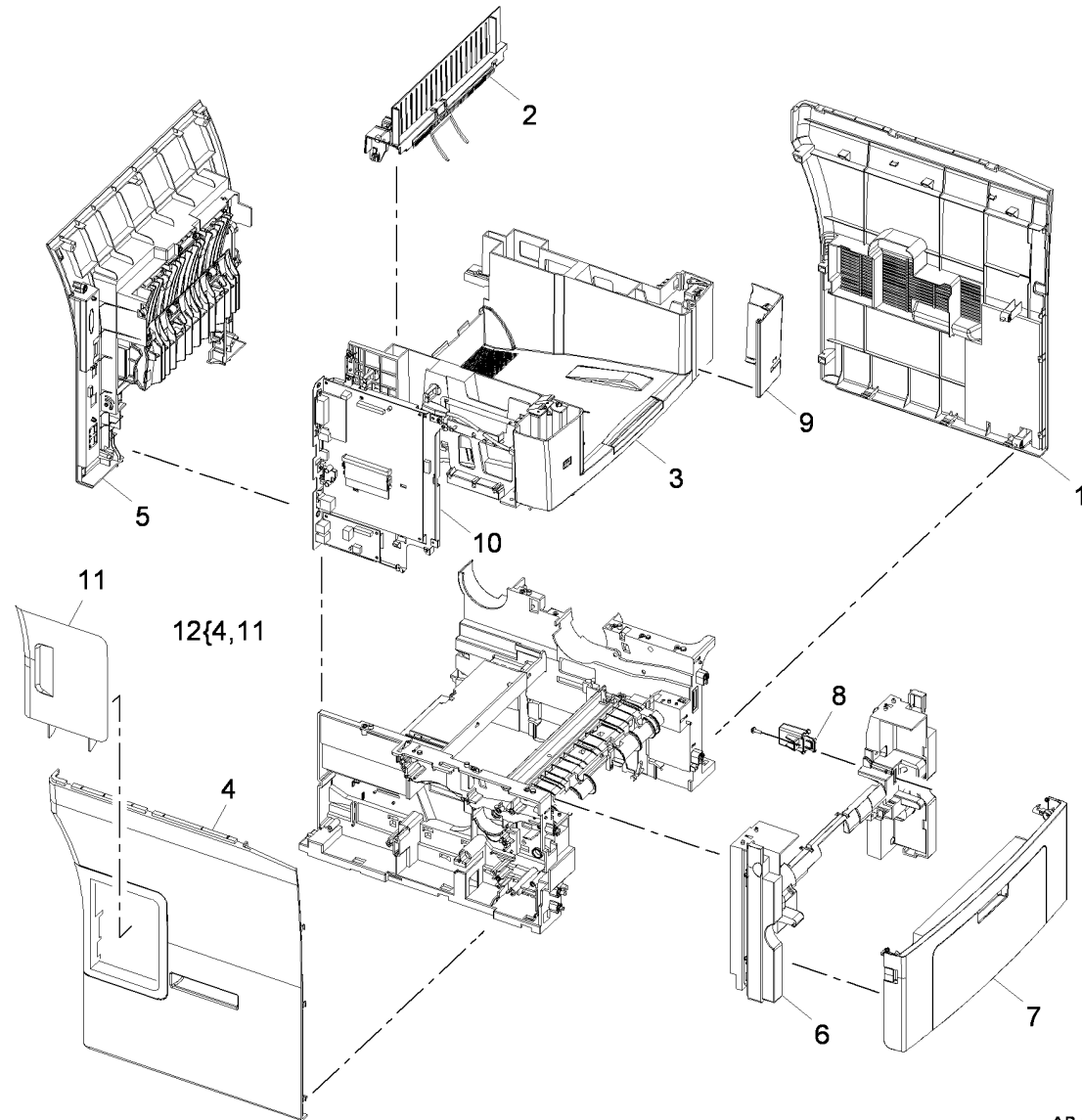

AP-8-1517-A